



# American Water Ski Association

## TECHNICAL CONTROLLERS' HANDBOOK

Revised 2007

Contributions By: Merle Vasbinder, Tom Dusin, Gene Davis, Dave Clark, Ed Brazil and others.

### TABLE OF CONTENTS

- 1) Introduction
  - i) Technical Controller (Homologator) rating System
  - ii) General philosophy of measurement & tolerances
- 2) Slalom Requirements
  - i) Course certification – Surveying
  - ii) Buoys
  - iii) Checking a previously surveyed course
  - iv) Judging Areas
  - v) Video Requirements
- 3) Jump Requirements
  - i) Course Certification – Surveying
  - ii) Jump Ramp
  - iii) Meter Locations
  - iv) Video/Computer Measurement
- 4) Trick Requirements
  - i) Course Certification
  - ii) Judging Area
  - iii) Timing Methods
- 5) Tow Ropes
  - i) Slalom
  - ii) Jump
  - iii) Handles
- 6) Timing Devices
  - i) Electronic Boat Timing
  - ii) Video Trick Timers
- 7) Communications
- 8) During the tournament
- 9) Records
  - i) Slalom
  - ii) Jump
  - iii) Trick
- 10) Appendices
  - i) Towline dimensions
  - ii) Slalom Course diagram
  - iii) Jump course diagram
  - iv) Jump ramp measuring chart
  - v) Trick course diagram
  - vi) Tournament classification requirements
  - vii) Slalom timing chart
  - viii) Jump timing chart
  - ix) Total Station PPM corrections
  - x) Prism Offsets
  - xi) Tripod setup
  - xii) Surveying instructions
  - xiii) Survey exercise
  - xiv) Homologation Dossier
  - xv) Homologation Notice
  - xvi) Technical Controller Application



# American Water Ski Association

## TECHNICAL CONTROLLERS' HANDBOOK

Revised 2007

Contributions By: Merle Vasbinder, Tom Dusin, Gene Davis, Dave Clark, Ed Brazil and others.

### 1) Introduction

To become a Technical Controller (TC) or Homologator, an individual must apply for a rating through the American Water Ski Association. A list of quantitative requirements must be completed prior to becoming a certified Technical Controller. These requirements require attendance at a Technical Controller's clinic, in addition to completing various technical functions under the supervision of a certified technical controller.

*Homologation (from the verb homologate, meaning to approve or confirm officially) is the certification of a product or specification to indicate that it meets regulatory standards.*

Your responsibility as a Technical Controller or Homologator is to ensure that everyone has a fair opportunity to compete, and particularly to ensure that all standards at your event are equal to any other record capable tournament. The Technical Controller must be aware of both AWSA and International Water Ski Federation (IWSF) record standards, rules and their application. The TC's job is to measure the tournament organizer supplied site and equipment as a Homologator; not to be obligated to swim for the purpose of pulling down buoys or finding a tournament handle, shock tube, rope, ect. or bring a truckload of equipment with all the other stuff we are all guilty of being holed into.

### 2) Slalom Course Requirements

One of the most challenging tasks of the TC is to approve the slalom course that has been installed at the tournament site. There are several ways in which this may be accomplished. Depending on the class of tournament, certification can be as simple as using a tape measure, or as complex as using surveying techniques. Whatever the case, timing of the certification process is most important. Certification for class N, I, or C tournaments should be performed well enough on advance to accommodate the physical constraints of the site. Section 15.03(b) of the AWSA rule book outlines the requirements.

#### 15.03 Certification of Competition Courses

- a) The Technical Committee shall devise and publish standards for the certification of competition courses. Such standards shall require that all slalom and jump course buoys and the jump ramp and meter station pivot centers be located by appropriate survey methods. The inter-relationships among these objects shall be derived there from, and must be within the location tolerances shown in the Official Slalom and Jump Course Diagrams in the Appendix.
- b) The competition slalom and jump courses required for the events scheduled for the tournament must be certified in advance of the tournament by either one of the following two procedures:
  - (1) The slalom course and the jump course shall be surveyed by either a licensed surveyor, acting as such, or by a person independent of the tournament sponsors who satisfies the Chairman of the Technical Committee as to his competence prior to the survey, no more than 90 but no less than 30 days prior to the tournament.
  - (2) The survey and supporting detail shall be forwarded to the Appointed Technical Controller for the tournament at least one week prior to the tournament.



# American Water Ski Association

## TECHNICAL CONTROLLERS' HANDBOOK

Revised 2007

Contributions By: Merle Vasbinder, Tom Dusin, Gene Davis, Dave Clark, Ed Brazil and others.

If the pre-survey option is exercised, the rule book time constraints must be followed, so that any necessary corrections may be accomplished.

In addition to checking the accuracy of the buoy positions, the method of attachment should be checked for compliance with section 10.16(b),

### 10.16 Slalom Equipment and Definitions

- a) Buoys: For specifications see Rule 8.09.
  - 1) Skier buoys and the end gate buoys shall be bright red or orange.
  - 2) The interior boat guide buoys shall be bright yellow, except that the 55m alignment buoys outside the course on either end shall be of a contrasting color (green is recommended).
  - 3) For Record Capability tournaments, buoys must either be individually anchored to the bottom or suspended on cross-ways lines anchored on opposite sides of the course. Floating "cable" courses which are anchored solely at the ends of a centerline cable are not permitted for Record Capability tournaments.

### 8.09 Buoys

- a) Buoys must have provisions for attaching anchor lines, and must be fastened by means of a tensioning device.
- b) Boat guide buoys may be spherical, cylindrical, or bullet-shaped. Spherical buoys shall be 22 - 28 cm (8¾" to 11") in diameter (23 cm (9") recommended), and fastened so that they have 11 - 17 cm (4-3/8" to 6¾") of height out of the water (11.5 cm (4½") recommended). Non-spherical types may have a cross-sectional area of 75 - 450 square cm (12 - 70 square inches), shall appear vertical, and shall be 15 - 30 cm (6 - 12") exposed above the water. Boat path alignment gates where required in Slalom, shall consist of cylindrical buoys of a color contrasting to the official course buoys (green recommended) and shall be placed outside the official course at either end, at a distance of 55 meters beyond the entrance gates, and at the 1.15-meter width of the interior boat guide buoys.
- c) Skier buoys shall be generally spherical in shape and 20 - 28 cm (7.8" to 11") in diameter (20 cm (7.8") recommended), and fastened so that they have 10 - 17 cm (3.9" to 6¾") of height out of the water (10 cm (3.9") recommended). They shall be of lightweight, pliable material with a smooth, exposed surface.
- d) End gates in the slalom course shall be provided with an elastic device or equivalent which will allow the buoys to rise and fall under tension with the passage of the wakes. These end gate buoys shall be the same size as skier buoys and shall be fastened so that they have the same height out of water.
- e) For colors and placements of buoys see Rules 9.16(d), 10.16(b) and the diagrams in the Appendix.



# American Water Ski Association

## TECHNICAL CONTROLLERS' HANDBOOK

Revised 2007

Contributions By: Merle Vasbinder, Tom Dusin, Gene Davis, Dave Clark, Ed Brazil and others.

The easiest way to measure these is to fabricate plywood measuring templates or polypropylene rope rings of the proper size. The rings are quite easy to make, and accommodate buoys which are less than perfectly round. It is best if you can adjust the size and height during middle to late afternoon so that the sun shining on the buoys will not cause them to "grow" at some later time. During this operation also check and size replacement buoys. This is also a good time to discuss with the tournament sponsor the procedure for replacing buoys that are pulled out or come loose during the event. Marking the recommended and minimum heights on the buoys makes them easy to check when replaced and during the tournament. Using cylindrical buoys for boat guides generally greatly reduces the number of buoys that must be replaced.

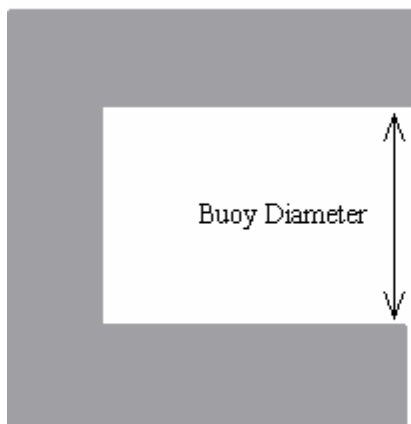

Plywood Caliper

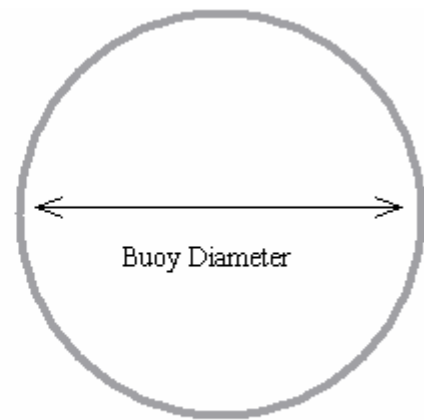

Rope measuring ring



# American Water Ski Association

## TECHNICAL CONTROLLERS' HANDBOOK

Revised 2007

Contributions By: Merle Vasbinder, Tom Dusin, Gene Davis, Dave Clark, Ed Brazil and others.

The timing segment lengths and tower locations in accordance with applicable sections of the AWSA rule book.

### Official Slalom Course

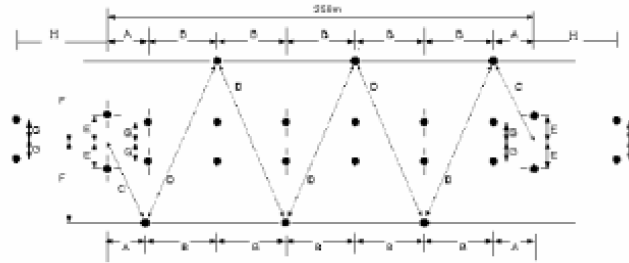

Dim	Metric			English		
	Actual	Minimum	Maximum	Actual	Minimum	Maximum
OA	259m	258.353m	259.648m	849' 8 <sup>7</sup> / <sub>8</sub> "	847' 7 <sup>3</sup> / <sub>8</sub> "	851' 10 <sup>7</sup> / <sub>8</sub> "
A	27m	26.865m	27.135m	88' 7"	88' 1 <sup>7</sup> / <sub>8</sub> "	89' 1 <sup>1</sup> / <sub>4</sub> "
B	41m	40.795m	41.205m	134' 6 <sup>1</sup> / <sub>8</sub> "	133' 10 <sup>1</sup> / <sub>8</sub> "	135' 2 <sup>1</sup> / <sub>4</sub> "
C	29.347m	29.2m	29.494m	96' 3 <sup>3</sup> / <sub>8</sub> "	95' 9 <sup>3</sup> / <sub>8</sub> "	96' 9 <sup>1</sup> / <sub>8</sub> "
D	47.011m	46.776m	47.246m	154' 2 <sup>3</sup> / <sub>4</sub> "	153' 5 <sup>3</sup> / <sub>8</sub> "	155' 1 <sup>1</sup> / <sub>8</sub> "
E	1.25m	1.188m	1.313m	4' 1 <sup>1</sup> / <sub>4</sub> "	3' 10 <sup>3</sup> / <sub>4</sub> "	4' 3 <sup>3</sup> / <sub>4</sub> "
F	11.5m	11.385m	11.616m	37' 8 <sup>3</sup> / <sub>4</sub> "	37' 4 <sup>1</sup> / <sub>4</sub> "	38' 1 <sup>1</sup> / <sub>8</sub> "
G	1.15m	1.035m	1.265m	3' 9 <sup>1</sup> / <sub>4</sub> "	3' 4 <sup>3</sup> / <sub>4</sub> "	4' 1 <sup>3</sup> / <sub>4</sub> "
H	55m	54.725m	55.275m	180' 5 <sup>3</sup> / <sub>8</sub> "	179' 6 <sup>1</sup> / <sub>2</sub> "	181' 4 <sup>1</sup> / <sub>4</sub> "

#### Tolerances (±)

¼% on 259 m	5% on E
½% on A,B,C,D,H	10% on G
1% on F	

At all Record Capability tournaments (E,L,R) including Regionals and Nationals, boat path alignment gates consisting of cylindrical buoys (green recommended) of a color contrasting to the official course buoys, and placed outside the official course at a distance of 55m (180' 5<sup>3</sup>/<sub>8</sub>"') before the end and at either end and at the 1.15m (3' 9<sup>1</sup>/<sub>4</sub>"') width of the interior boat guide buoys—are mandatory. Where practical, their use is recommended at all other events.

#### 10.16 Slalom Equipment and Definitions (Towers)

- Slalom Judging Area:** An elevated observation point that provides an unobstructed view of the slalom course, at least 3 meters (10') above the water shall be provided. More than one such observation point is permissible and desirable. At least two, on opposite sides of the course, are required for Record Capability tournaments and recommended for all other tournaments. If an observation point is located more than 100 feet back from the course centerline, it is recommended that it be elevated approximately ten percent above the water (one foot in height for each ten feet back from the course centerline). It is also recommended that each observation point be placed along a line extending at a 44-degree angle from the center of the entrance gate at that end of the course. See also Rule 10.08(b) for an optional method of judging slalom. In Class C tournaments and below, if no slalom towers are used, the judges shall be stationed with the best possible view of the course.



# American Water Ski Association

## TECHNICAL CONTROLLERS' HANDBOOK

Revised 2007

Contributions By: Merle Vasbinder, Tom Dusin, Gene Davis, Dave Clark, Ed Brazil and others.

### Checking a Previously Surveyed Course

If you are to be TC at a site on which the course has been previously measured, or surveyed (class E, L, and R), you are still obligated to verify the accuracy of the course.

The most accurate means of doing this would be to take your own set of measurements or to complete your own survey. If this is not possible, spot checks of critical measurements and/or setting up an instrument to verify angles produced in the original survey should be performed. If pre-measured polypropylene triangulation ropes are used to measure the course, they must be stretched and rechecked while still wet. When checking, the anticipated "in water" tension should be applied. Using these precautions, this method has been documented to be very accurate. (Polypropylene ropes will shrink as much as 5% if stored dry for extended periods of time.)

For verifying the accuracy of record capable courses which have been surveyed within the time constraints of rule 15.03 of the AWSA rule book, or to verify courses for Class C tournaments, there is a two point survey reduction program available from AWSA, which can be used to accomplish these tasks. In the case of Record tournaments and deviations from the established standards, the course must be verified by either a three-point or single-point EDM survey.

#### 15.03 Certification of Competition Courses

- c) The Technical Committee shall devise and publish standards for the certification of competition courses. Such standards shall require that all slalom and jump course buoys and the jump ramp and meter station pivot centers be located by appropriate survey methods. The inter-relationships among these objects shall be derived there from, and must be within the location tolerances shown in the Official Slalom and Jump Course Diagrams in the Appendix.
- d) The competition slalom and jump courses required for the events scheduled for the tournament must be certified in advance of the tournament by either one of the following two procedures:
  - (1) The slalom course and the jump course shall be surveyed by either a licensed surveyor, acting as such, or by a person independent of the tournament sponsors who satisfies the Chairman of the Technical Committee as to his competence prior to the survey, no more than 90 but no less than 30 days prior to the tournament.
  - (2) The survey and supporting detail shall be forwarded to the Appointed Technical Controller for the tournament at least one week prior to the tournament.

Another method of checking the accuracy of slalom courses for class "C" events is to measure the width of buoys 1, 2, 5, 6 with a tape and then visually sight each skier buoy line to ensure that the buoys line up. When using this method, it is also recommended that some of the distances between the gates be checked to verify the length of the course.

### Judging Areas

Section 10.16(a) of the AWSA rule book outlines the requirements to the slalom judging areas.

- a) Slalom Judging Area: An elevated observation point that provides an unobstructed view of the slalom course, at least 3 meters (10') above the water shall be provided. More than one such observation point is permissible and desirable. At least two, on opposite sides of the course, are required for Record Capability tournaments and recommended for all other tournaments. If an observation point is located more than 100 feet back from the course centerline, it is recommended that it be elevated approximately ten percent above the water (one foot in height for each ten feet back from the course



# American Water Ski Association

## TECHNICAL CONTROLLERS' HANDBOOK

Revised 2007

Contributions By: Merle Vasbinder, Tom Dusin, Gene Davis, Dave Clark, Ed Brazil and others.

centerline). It is also recommended that each observation point be placed along a line extending at a 44-degree angle from the center of the entrance gate at that end of the course. See also Rule 10.08(b) for an optional method of judging slalom. In Class C tournaments and below, if no slalom towers are used, the judges shall be stationed with the best possible view of the course.

**Recent clarification for the elevated observation point indicates the floor of the platform be at least 10' above the water, *not the anticipated eye level of the judge.***

AWSA rule 10.08(b) outlines optional methods of placing a single tower at midpoint of the slalom course with recorded video feeds from each end of the slalom course.

**(2004) IWSF rule 17.03 allows the use of only boat video with a centrally located tower.**

### 10.08 Officials

- b) Tower Judges: There shall be four event judges stationed in the slalom judging area in accordance with Rule 10.16(a). Each tower judge shall independently judge the credit to be received by the skier in accordance with Rule 10.12, and shall communicate his results to the scorers immediately after each pass. The entrance and exit gates shall be judged by the boat judge and the two judges with the best view of each gate, (except when optional video gate judging from a central tower is used), as determined by the Chief Judge. Each event judge must continue scoring a run even though he feels the skier missed a gate or buoy. As an option, two judges may be used in slalom with the same height requirements referenced above.

***It is recommended that the two tower judges be placed on opposite sides of the course.***

Additionally, there shall be video feeds from cameras located at each end of the slalom course, positioned with an unobstructed view of the entrance gates, and placed at the required angle to the gates at least 3 meters (10') above the water. The cameras shall be adjusted to show both gates in clear focus, and equipped with optical (not digital) magnification of sufficient power to display the gate at least 1/6th of the full width of the screen (1/3 width or larger is recommended). If a camera is located more than 100 feet back from the course centerline, it is recommended that it be elevated approximately ten percent above the water (one foot in height for each ten feet back from the course centerline). These camera feeds shall be displayed on a monitor and taped. Each judge shall independently call the entrance gate by observing the monitor. If one or both judges did not observe the entrance gate, or the two judges should disagree, then the judge(s) would replay the video (at normal speed, slow motion, or frame-by-frame) to make the call. (If video replay malfunctions, the boat judge shall call the gates.) The Appointed Judges shall determine the time at which the video review will take place and if the video review is to be after the conclusion of the skier's last pass, then the skier shall be advised that he is continuing at risk, pending the video review. If the judges disagree after having reviewed the video, the Chief Judge (or his designee) will cast the deciding vote. The exit gate will be viewed directly, but the video may be used by one or both judges to resolve any questions. ***The use of video gate cameras, as describes above, shall be mandatory at the US Nationals, regardless if using 3 or 5 judges.***

A camera feed from the boat may be used and be monitored on the tower by another judge who will advise the Chief Judge if he disagrees with the event judges' decision. In this case, the Chief Judge will ask the event judges to review that video. This is a separate optional rule and may be used with 3 or 5 judges, or need not be used. The Appointed Judges shall determine the time at which the video review will take place and



# American Water Ski Association

## TECHNICAL CONTROLLERS' HANDBOOK

Revised 2007

Contributions By: Merle Vasbinder, Tom Dusin, Gene Davis, Dave Clark, Ed Brazil and others.

if the video review is to be after the conclusion of the skier's last pass, then the skier shall be advised that he is continuing at risk, pending the video review.

If a skier or team representative believes that there was an error in the score, he may challenge it by notifying the Chief Judge before the next skier goes out, and by putting up \$100. The Chief Judge and a designated review judge will review the video (**boat or gate video**). If they both agree on a score, that will be the given score. If they disagree, or agree that the video does not clearly overrule the score given by the judges, then that score will stand. The \$100 will be returned only if the original score was changed. If the funds are not returned to the skier, they shall be forwarded to the AWSEF as a contribution in the skier's name.

For Class C tournaments and below, at the option of the Chief Judge, three judges (two towers and one boat) rather than five may be used to score slalom **and video gate cameras are not required**.





# American Water Ski Association

## TECHNICAL CONTROLLERS' HANDBOOK

Revised 2007

Contributions By: Merle Vasbinder, Tom Dusin, Gene Davis, Dave Clark, Ed Brazil and others.

### Video requirements

AWSA rule 15.06(d) specifies the video necessary for record qualification.

#### (d) Slalom Requirements:

(1) End-course video shall be recorded in the Slalom event for all passes. A rigidly mounted video camera shall be operated from a point on the centerline on at least one end of the slalom course, adjusted to show all of the boat guides in clear focus and equipped with optical (not digital) magnification of sufficient power to display the far entrance/exit gate occupying at least 1/6th of the full width of the screen (1/3 width or larger is recommended). It is recommended that a radio receiver be placed by the recorder so that all radio transmissions are recorded on the audio track that the skier's name and speed and/or line length be announced on each pass, and the actual times recorded by the official timing devices also be announced. It is further recommended that a monitor be placed in the judges tower, and that this be observed by an official designated by the Chief Judge for compliance with Rule 10.07 during any critical passes involving either EP ratings or potential records. The video tape recordings of non-record passes (on standard size VHS cassette) shall be submitted to the Regions Driver Committee Representative.

- (3) The judging area on each side of the course shall be located within 44 degrees  $\pm$  3 degrees from the course centerline (rotated clockwise about a point at the center of the entrance gate to the left end of the course as seen from that observation point). If it is not feasible to place the judges' tower at the prescribed angle, a video camera may be mounted at the proper angle and the live signal fed to a monitor in the judges' tower, so that the appropriate event judge(s) can observe the gates. Judgment on the gates will be made by viewing the monitor. The signal will be taped so that review is possible. See also Rule 10.08(b) for an optional method of judging slalom.

**IWSF (2003) A black 5 cm (approx) wide strip up the middle for the windshield will be used to show up on the end course video. If the boat already has a visible center mark on the windshield this is not necessary. A visible mark would be a center seam between two halves of the windshield or a center swing out window that would have vertical seams on either side of center. The mark, if required would only need to come up approximately half way to the top of the windshield, but be clearly visible in the end course video.**

The video tape (standard size VHS cassette) and the original judges scoring sheets shall accompany the record application.

(b) For a Slalom record to be considered, video of the boat path is required (see Rule 15.07(d) below) for all passes. The video tape (on standard size VHS cassette) shall accompany the record application. For Slalom the final two passes on the video tape will be examined by the Technical Chairman or his designee to verify that the boat path is within the following deviation specifications: Maximum deviation of the boat on approach to each buoy/gate is 20 cm (8 inches) toward the side of the skier buoy. The Total Cumulative Deviation (the algebraic sum of the individual deviations) is to be evaluated based on the score for the pass, as follows:



# American Water Ski Association

## TECHNICAL CONTROLLERS' HANDBOOK

Revised 2007

Contributions By: Merle Vasbinder, Tom Dusin, Gene Davis, Dave Clark, Ed Brazil and others.

Score	Limit	Score	Limit
0.25 - 1.00	20 cm	3.25 - 4.00	40 cm
1.25 - 2.00	28 cm	4.25 - 5.00	45 cm
2.25 - 3.00	35 cm	5.25 - 6.00	49 cm

### 3) Jump Requirements

#### Course Certification

All that was said about certifying slalom courses also applies to jump courses. When a survey is required, often times the jump and slalom course are close enough together to be surveyed at the same time. This is generally more efficient, however, it is very easy to confuse buoys, and the baseline used to measure both courses may not be the best for either one in particular. If you are using the AWSA approved program which includes a setup for the jump meters, be sure that you are using the correct combination for the site, as meter location relative to the survey point(s) is somewhat critical, and using the wrong version can cause errors. These problems are discussed in more detail in Appendix E.

#### 15.03 Certification of Competition Courses

- e) The Technical Committee shall devise and publish standards for the certification of competition courses. Such standards shall require that all slalom and jump course buoys and the jump ramp and meter station pivot centers be located by appropriate survey methods. The inter-relationships among these objects shall be derived there from, and must be within the location tolerances shown in the Official Slalom and Jump Course Diagrams in the Appendix.
- f) The competition slalom and jump courses required for the events scheduled for the tournament must be certified in advance of the tournament by either one of the following two procedures:
  - (1) The slalom course and the jump course shall be surveyed by either a licensed surveyor, acting as such, or by a person independent of the tournament sponsors who satisfies the Chairman of the Technical Committee as to his competence prior to the survey, no more than 90 but no less than 30 days prior to the tournament.
  - (2) The survey and supporting detail shall be forwarded to the Appointed Technical Controller for the tournament at least one week prior to the tournament.

If the pre-survey option is exercised, the rule book time constraints must be followed, so that any necessary corrections may be accomplished.



# American Water Ski Association

## TECHNICAL CONTROLLERS' HANDBOOK

Revised 2007

Contributions By: Merle Vasbinder, Tom Dusin, Gene Davis, Dave Clark, Ed Brazil and others.

### Official Jump Course Diagram

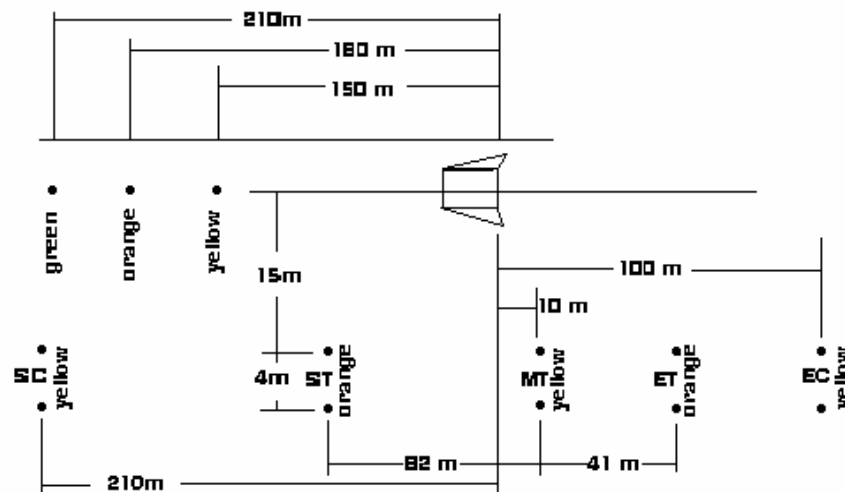

Jump Course Dimensions and Tolerances		
Dimensions	Tolerances	Range
210m (688' 11 <sup>3</sup> / <sub>4</sub> "	1.0%	207.9m - 212.1m (682' 1" - 695' 10 5/8")
180m (590' 6 1/2"	1.0%	178.2 - 181.8m (584' 7 3/4" - 596' 5 1/2")
150m (492' 1 1/2"	1.0%	148.5 - 151.5m (487' 2 1/2" - 497' 1/2")
100m (328' 1"		90.0 - 102.0m (301' 8 1/4" - 334' 7 3/4")
82m (269' 1/4"	0.5%	81.59 - 82.41m (267' 8 1/4" - 270' 4 1/2")
41m (134' 6 1/4"	0.5%	40.795 - 41.205m (133' 10" - 135' 2 1/4")
4m (13' 1 1/2"	2.5%	3.9 - 4.1m (12' 9 1/2" - 13' 5 1/2")
15m (49' 2 1/2"		
to ramp high center	1.0%	14.85 - 15.15m (48' 8 3/4" - 49' 8 1/2")
- to 150m, 180m	± .5m	14.50 - 15.50m (47' 6 3/4" - 50' 10 1/4")
10m (32' 9 3/4"	2%	9.8 - 10.2m (32' 1 3/4" - 33' 5 1/2")

The ramp must be parallel to the jump course and slightly open. The tolerance for standard jumping is between **+1.00** degrees and **+2.50** degrees open, **with +2.00 recommended**. Open means that the high end of the ramp is turned away from the jump course while the center of the high end remains on the 15m dimension.

The 15 MT buoy may be sunk below 1/2 of its volume. However, it must be clearly visible.



# American Water Ski Association

## TECHNICAL CONTROLLERS' HANDBOOK

Revised 2007

Contributions By: Merle Vasbinder, Tom Dusin, Gene Davis, Dave Clark, Ed Brazil and others.

### Jump Ramp Specifications

#### Angle

Measuring the angle of the jump to the jump course is a task that is best done by surveying methods. When using survey methods, several points are located on the jump along with position of the buoys in the jump course, or a point is located on shore on the extension of the high end of the ramp (HEXM) or high end extended mark. This information is entered into one of several AWSA approved data reduction routines to solve for this angle (Appendix F). The maximum amount open (low end of the ramp towards the jump course) permitted is 1 – 2.5 degrees as specified by the Official Jump Course diagram in the AWSA rule book. The greatest concern is that the ramp not be "closed", (low end of the ramp away from the jump course) to the skier. The same limitations apply when the jump angle is calculated manually.

**IWSF (2004) 1 – 2.5 degrees open, with 2 degrees recommended.**

When performing this measurement manually, a line must be stretched from the 15-meter start timing buoy to the 15-meter mid-timing buoy. Measurements then must be taken from the high end of the jump ( $D_H$ ) to the line and from the low end of the jump ( $D_L$ ) to the line. The open angle can be calculated from the relationship: open angle = inverse tangent  $((D_H - D_L) / L_j)$  where  $L_j$  is the distance from  $D_H$  to  $D_L$ .

This assumes the 15 meter buoy line is straight. If the measurements show the low end to be further from the 15 meter buoy line than the high end, the jump is closed and corrections should be made before proceeding further. As a rule of thumb, the low end of the jump should not be more than five (5) inches closer to the jump course than the high end.

The AWSA rule book outlines the specifications for the jump ramp. Any deficiencies in the condition of the ramp should be reported to the tournament sponsor and/or the safety director for correction. During the inspection, the jump ramp anchoring system should be inspected and most importantly, be certain that at least 20 inches of the low end ramp surface is under the water. Although there is not at the present time a specified requirement, it is advisable to have someone stand on the ramp at various places to ensure that the ramp has sufficient flotation and that skier coming onto the ramp will not cause excessive deflection.

During the inspection is a good time to check raising and lowering of the ramp. Check the length/height ratios of each ramp setting to be used to ensure compliance with the AWSA rule book. Additionally, discuss the height changing procedure with the tournament sponsor. If the height is changed by installing blocks under the support mechanism, be certain that sufficient blocks are available for all combinations. For infinite setting ramps, if you can mark the height setting to be used during the tournament, you will probably save some time. It may be that additional flotation will be required under the low end of the ramp in order to achieve the proper (desired) length/height ratios. If this is the case, determine the requirements at this time and insure its availability. Several items which will provide the additional flotation are



# American Water Ski Association

## TECHNICAL CONTROLLERS' HANDBOOK

Revised 2007

Contributions By: Merle Vasbinder, Tom Dusin, Gene Davis, Dave Clark, Ed Brazil and others.

Styrofoam, truck/car inner tubes, old inflatable buoys, and sealable cans or buckets filled with air. If the tournament requirements include the "six-foot" ramp, i.e., the .275 aspect ration, determine what it will take to get the ramp to that setting, as on many ramps, this length/height ratio is difficult to achieve. Remember, that when setting the height and angle of the jumping ramp, the Technical Controller is obliged to set the jump as close as possible to the rule book specifications as follows.

### **AWSA 9.16 Jumping Equipment and Definitions**

- (a) Jump Meters: Meter stations shall be equipped with AWSA-approved protractors and sighting arms. Sightings from each meter shall be taken to the sighting mark on the ramp (Rule 9.16(c) (9)) and to the 15ET buoy. The upper and lower meters at each station must not differ on either of these sightings by more than 0.1 degree for Record Capability tournaments, or not more than 0.2 degree at Class C tournaments. For both sightings, the average of the readings at each station shall be taken, and must produce a triangle size on both these points (as per Rule 9.12(c)(2)) no greater than 15 cm (6") for Record Capability tournaments, or no greater than 23 cm (9") for Class C tournaments.
- (b) Distance Derivation Devices: Distances shall be derived either by a computing device, or on a scale model manual plotting board which has been set up and verified according to guidelines described in the AWSA Technical Handbook. For Record Capability tournaments, a computing device must be used as the primary method. Where a computing device is used, either the manual plotting board or an independently-powered computing device shall be provided as a backup measuring device, and should it become necessary to use that backup device, the distances it produces shall be official. Any such computing devices shall be checked by the Chief Judge or his designate, and must be shown to produce the listed results for all the test cases that appear in the Computer Benchmark section of the Appendix.
- (c) The Jump Ramp: The jump ramp shall be an inclined plane with mounted aprons set at an angle in relation to the ramp. The ramp shall meet the following specifications:
- (1) Width: 3.7 meters (12') to 4.3 meters (14'1¼") at all points. 4.3 meters is the preferred width.
  - (2) Length Out of Water: 6.4 meters (21') to 6.8 meters (22' 3¾") at all points.
  - (3) Length Under Water: 50 cm (20") minimum.
  - (4) The following ratios of ramp height at take-off edge to ramp length out of water shall apply: Men 1 and 2 jumpers will have the option of choosing either the .255 or .235 ramp; Boys 3 shall use the .235 ramp unless they can show a certified result of a jump of 38 m (125 feet) on the .235 ramp, in which case they may opt to jump on a .255 ramp; Open Women shall use the .235 ramp unless they can show a certified result from a Record Capability tournament of a jump of 40 m (132 feet) on the .235 ramp, in which case they may opt to jump on a .255 ramp; Open Men will have the option of choosing either the .271 or .255 ramp; and all other divisions will be set at .235. All of these ratios shall be set to within  $\pm .003$  for all Record Capability tournaments, or to within  $\pm .005$  for all other tournaments. (See Ramp Setting Chart in the Appendix.) At the option of the sponsoring club, any division may jump at a ramp ratio of less than .235.
  - (5) Surface: The surface must be flat with a maximum deviation of 5 cm (2") from a plane, (2.5 cm) (1") for Record Capability tournaments. For Class N tournaments, greater deviations from a plane may be allowed, but this is not recommended.
  - (6) Aprons: Aprons shall extend the full length of the ramp and shall be at least 20 cm (8") under water when the ramp is raised to its full height. A left-sided apron is not required. The recommended apron angle is 30 degrees from vertical. For the first 1/3 of the apron at and below the water, the curtain may be approximately 60 degrees from vertical. It shall be radiused and blended to the surface to prevent skis from catching.
  - (7) Ramp Markings: 6.4-meter and 6.7-meter (21' and 22') length markings, clearly identified, shall be placed on the aprons and/or ramp surface so that they are readily visible. Extra marks, if identified, are allowed and desirable.
  - (8) Color Specifications: The ramp aprons and ramp surface shall be of different colors, both of which shall be different from the water surface. The ramp surface shall be one solid color without borders or decorations of any sort.
  - (9) Vertical Line: A 1 - 3 cm (¼" - 1") wide vertical line of contrasting color shall be plainly marked or painted at the center of and just below the take-off edge for meter



# American Water Ski Association

## TECHNICAL CONTROLLERS' HANDBOOK

Revised 2007

Contributions By: Merle Vasbinder, Tom Dusin, Gene Davis, Dave Clark, Ed Brazil and others.

sighting purposes. This vertical line may extend over onto the jump surface not more than 8 cm (3") to facilitate locating the centerline during surveys. The jump ramp must be securely anchored in place such that the center take-off edge will not vary more than the sighted width of the crosshair on all meters after coming to static rest. "Static rest" is the position assumed by the ramp in ambient water not affected by boat wakes, skier's wakes, or backwash.

(The recommended length out of water should be set as long as possible within the tolerance to produce a ramp slope that is as flat as the tolerance allows.)

### **Jump distance measurement**

Current IWSF rules require the use of video measurement for class "R" events (IWSF 16.03 c). Three systems are currently approved. However, ranking list "L" tournaments and below allow the option of using a shore mounted three meter Johnson system. The Johnson system can determine distances with either a manual or electronic masterboard.

### **Electronic Masterboard**

This is another name for a computer. Record Capability tournaments ("E" and "L") require the use of a computer to calculate jump distances. There are a number of different computer programs in use, and as TC your responsibility includes checking the program to be used to ensure that it meets the AWSA Computer Jump benchmark. If the tournament is using the WSTIMS program, which has been approved by AWSA, you need only check that it is an acceptable current version. AWSA can provide you with the acceptable versions of WSTIMS. If the tournament is to use another program, check it thoroughly to verify that it totally meets the requirements of the benchmark. When using a computer to calculate jumps, a manual masterboard is also required, unless a second, separately powered, i.e., battery operated, backup computer is available. The program in the backup computer must also be checked. While you are checking the computer and/or masterboard operation is also a good time to look at communications between the meters, the tow boat, and the computer or masterboard. One thing that sometimes develops is interference between the computer and the communication system(s). Check the systems with both of them operating to ensure there is not a conflict. At some point you should coordinate with the Chief Judge to develop a procedure for stopping the tow boat when they have not received the jump distance. Communications and boat patterns frequently have a major role to play in this operation. Another problem that sometimes occurs is interference between the public address system and calling in meter readings. If at all possible check on this aspect, and have an alternative available.

### **Manual Masterboard Setup**

Setting up a manual master board is really just creating a scale model of the jump metering system. To accomplish this task, certain information is required, which was obtained during the meter setup procedure. The distances required are those between each meter, more commonly known as Distance AC, AB, and BC, and the distance along the extended meter base line to the intersection of the extended top edge (high end) of the jumping ramp, known as Distance L. If the meter stands are





# American Water Ski Association

## TECHNICAL CONTROLLERS' HANDBOOK

Revised 2007

Contributions By: Merle Vasbinder, Tom Dusin, Gene Davis, Dave Clark, Ed Brazil and others.

not in a straight line, then knowing the distance that meter B is off the AC baseline or the distance that meter C is ahead of the AB base line, which ever case may apply, along with the distance along the baseline (the x-y coordinates of the meter) is very helpful. The angular measurements required are those between each meter, the sightings to the center of the jumping ramp, and the sightings to the 15m end timing ball. In addition to this information, some equipment is necessary. A board on which to construct the setup is essential. Any type of rigid material is acceptable, however it should be noted that being able to insert pins, tacks, nails, etc. is very helpful. The minimum dimensions for the board are dictated by the site, since you are constructing a 1/8th inch scale model of the jumping area. From a practical standpoint, a board 30 inches by 24 inches is probably an acceptable minimum. Three jump meter protractors, a landing area grid, a sufficient quantity of string or fishing line, three fasteners such as mentioned above, tape or some method of securing the protractors and grid to the board, and a measuring device round out the required equipment. A 1/8th inch architect's scale measuring up to 200 feet is also a very handy tool for constructing the masterboard.

Armed with this equipment and information, we are ready to begin our construction.

The first step is to establish a baseline. Pick a location on the board for meter A. Usually this is located somewhere on the bottom right hand side of the board. From meter A draw a line in the direction of meters B or C, depending on which you are using for your meter baseline. Using the scale of 1/8th inch equal to 1 foot, measure along this line the distance AC to locate meter C, and mark this point C. Then locate meter B. If the meters are in a straight line, you can simply measure along the base line from the meter a location the distance AB, and mark this point B. If the meters are not in a straight line, the task becomes somewhat more complex. If you were able to find the X & Y coordinates of meter B, using meter A as 0,0, locate point B using these coordinates. If not, it is time to install the protractors. Carefully place one protractor over point A, aligning the protractor baseline with the line on your board. Be certain that the center point on the protractor is exactly over point A and secure it to the board. Using one of your fasteners, attach a string to point A in such a manner that you can use the string to measure angles. Pull the string towards meter B, at the angle sighted from Meter A to Meter B. Repeat this procedure for point C, installing the protractor and string in a similar manner, again pulling the string towards meter B this time at the angle sighted from Meter C to Meter B. Mark the intersection of the two strings as point B. The scale measurements from point A to point B, and from point C to point B should equal the actual distances AB and BC.

If you fail to achieve this result within reasonable accuracy, repeat the process until you obtain acceptable results. Now place the remaining protractor on point B, with zero (0) degrees aligned with point A. Secure the protractor to the board, placing the center point directly over point B. Attach a string to point B, using one of the fasteners, and pull the string to point C. The reading should equal the angular sighting from Meter B to Meter C. If not, recheck your work for an error. After you have achieved the proper alignment of the protractors on the Masterboard; measure along your baseline from point A towards the jumping ramp. At distance L place a mark. Now take the strings coming from each point on the masterboard and align them with the sightings from the meter stations to the jumping ramp. It probably is best to plot each reading separately, and trace a line on the board. The intersection of these three lines is the location of the jumping ramp. If the intersection is not a



# American Water Ski Association

## TECHNICAL CONTROLLERS' HANDBOOK

Revised 2007

Contributions By: Merle Vasbinder, Tom Dusin, Gene Davis, Dave Clark, Ed Brazil and others.

perfect point, the triangle formed should be within the limits described above, i.e., 0.15m (6 inches) for Record Tournaments, or 0.23m (9 inches) for Class C tournaments. Again, if you do not achieve these results, recheck your work for errors. After achieving an acceptable triangle on the ramp, repeat the process for the 15 end timing ball. Similar results must be achieved, applying the same tolerances. You are now ready to install the distance measuring grid. Place the center point of the jumping ramp on the grid directly over the intersection of the sighting lines from the meter points. If the distance grid has the 15 end timing ball marked on it, (it is usually a cross), place this over the intersection of the sightings for the 15 end timing ball. The center point of the ramp is the critical mark, ensure that it is accurately placed. It is likely that the 15 end timing ball mark will not fall exactly in place, since there is a fairly large tolerance on ramp location up and down the course. Even if this occurs, you can still use this mark to align the grid by lining up the horizontal, (up and down course) leg of the 15 end timing ball with the intersection on your board. Now take a straight edge, and place it on the high end of the scale jumping ramp. This straight edge should very closely line up with the L distance mark on your base line. Slight variations are to be expected, since the L distance measurement is not a precision measurement. If you find major variations, recheck your work for errors. If your distance grid does not contain a mark for the 15 end timing ball, you may either calculate measure and mark one on the grid, or rely totally on the L distance method. Alignment of the grid is not critical, since the distance lines are in the form of concentric circles with the center of the jumping ramp as their center. Your masterboard is now setup and ready to use.

If the masterboard is to be used with two meter readers at each station, either in a record tournament as a backup, or in a class C tournament it is advisable to establish a "Spread Angle Test Range" for each meter station to evaluate differences between meter sightings on the same jump. Accomplishing this take in advance will save enormous amounts of time during a jumping event in which the manual masterboard is being used as the primary means of jump distance calculation. First you must establish a "Normal Landing Zone" this is an area five to seven feet wide which research has shown passes through the following points:

Down course distance:	30	60	90	120	150	180	210
Left of Ramp Center:	-12	6	16	21	21	18	12

This landing zone can also be marked on the masterboard with some type of marker for use in diagnosing large triangles. Generally the corner of the triangle which lies closest to the landing zone is made up from the sightings from the two meters whose readings are correct. This situation is only a generality, and should not be considered correct in every case.

To locate your "Spread Angle Test Range" (SATR), place the circle template that comes with the distance grid, or which you obtained from AWSA in the normal landing zone at the point which is closest to the meter station being evaluated and at the point which is farthest away from the meter station being evaluated. At each of these points find the difference in sighting angle to each side of the two foot circle on the circle template. Note or record these angular values. These values will be used to determine whether or not differences that occur between sightings from that meter station are acceptable, must be tested, or are unacceptable. If the difference between the sightings is less than the small end of the SATR, you can be certain that the readings are acceptable, and immediately use the average of the readings to





# American Water Ski Association

## TECHNICAL CONTROLLERS' HANDBOOK

Revised 2007

Contributions By: Merle Vasbinder, Tom Dusin, Gene Davis, Dave Clark, Ed Brazil and others.

calculate the difference. If the difference between the sightings is greater than the large end of the SATR you can be certain that the readings are unacceptable and must be tested in accordance with established procedures. If the difference between the sightings falls within the SATR, and then you will have to plot each of the readings from that meter and determine whether or not the spread produces a variation of more than two feet at the point of landing. To sight an example, when testing meter C within the normal landings zone, the small end of the SATR is determined to be 0.6 degrees. This condition would occur on a short jump distance, because it would be farthest away from meter C. In our example, the large end of the SATR is found to be 1.2 degrees. This would be on a long jump, because it would be closest to meter C. We have now established meter C's SATR as 0.6 to 1.2 degrees. This means that on any jump if the difference between sightings from meter C is 0.6 degrees or less, the average sighting can be used to calculate the jump distance without considering the spread. If the difference between the sightings is 1.2 degrees or greater, we must then test the readings in accordance with prescribed procedures. If the difference between the sightings is between 0.6 and 1.2 degrees, both sightings must be plotted to determine whether or not the spread produces a difference greater than two feet. You should establish this SATR for each meter station, and it is advisable to mark it on the masterboard for each meter station.

Your masterboard is now ready for use. It is to be used only as a backup to the computer in Record tournaments, but can be used as the primary means of jump distance measurement for Class C tournaments. Experience has shown that using a masterboard with two meter readers at each station is a cumbersome, time consuming, frustrating process which should be avoided if at all possible. If a masterboard is to be used at a class C tournament it is strongly suggested that only one meter reader be used at each station, as jumping will progress much quicker, even if re-rides occur because of large triangles.

### **Video Jump distance measurement**

The most commonly used video measurement in the US utilizes a computer program written by Bob Corson; this system relies on cameras mounted at elevated locations in similar locations as the Johnson meter stands. The cameras view the landing area and use a grid of buoys as reference markers to extrapolate the jump distance with the Corson computer program and computer video capture. The programs are available through the AWSA website. The following instructions detail the setup of the Corson system:



# American Water Ski Association

## TECHNICAL CONTROLLERS' HANDBOOK

Revised 2007

Contributions By: Merle Vasbinder, Tom Dusin, Gene Davis, Dave Clark, Ed Brazil and others.

### CORSON VIDEO JUMP MEASUREMENT SYSTEM

1. Plan your camera and grid layout(s) – the measurement “view(s)”:
  - a. Where feasible, use one of the recommended camera and reference grid layouts that are shown in the diagrams on the following pages.
  - b. For custom situations the VJVIEW16.wks planning tool; also available from the AWSA website can be used to explore key setup alternatives – most critically camera placement – see sample printouts. More detailed instructions included are within the spreadsheet template itself.
2. Install reference marker buoys and camera pylon(s), as planned.
3. Establish the exact water surface coordinates of reference grid buoys and check points – use one of three methods, as appropriate for class of competition:
  - a. Take manual measurements between reference grid buoys, and then use the VJGRID11.wks spreadsheet – recording form and examples on following pages.
  - b. Use existing meter system and WSTIMS setup program to plot reference buoys – record X and Y coordinates reported for each point sighted.
  - c. Survey the reference grid along with the rest of the jump course – required for class “R” – see the sample printout on following pages.
4. Set up shore-based equipment and arrange it for use:
  - a. Prepare computer equipment and turn on and hook up video cables(s).
  - b. Install camera(s) and verify view(s) – adjust Zoom, Tilt & Pan as necessary.
5. Prepare measurement setup – repeats steps for each view, if more than one:
  - a. Verify that camera view covers the intended landing area as planned.
  - b. Input the grid point coordinates for this grid, if not previously saved.
  - c. Mark the locations of the grid reference buoys on the display screen.
  - d. Run the “Accuracy Check” procedure – verify results for class.
  - e. Verify the coordinates of the independent check point.
6. Run Jumping Events:
  - a. Periodically verify that reference marks are still centered on buoy images.
  - b. Measure jump distances with accuracy and confidence!



# American Water Ski Association

## TECHNICAL CONTROLLERS' HANDBOOK

Revised 2007

Contributions By: Merle Vasbinder, Tom Dusin, Gene Davis, Dave Clark, Ed Brazil and others.

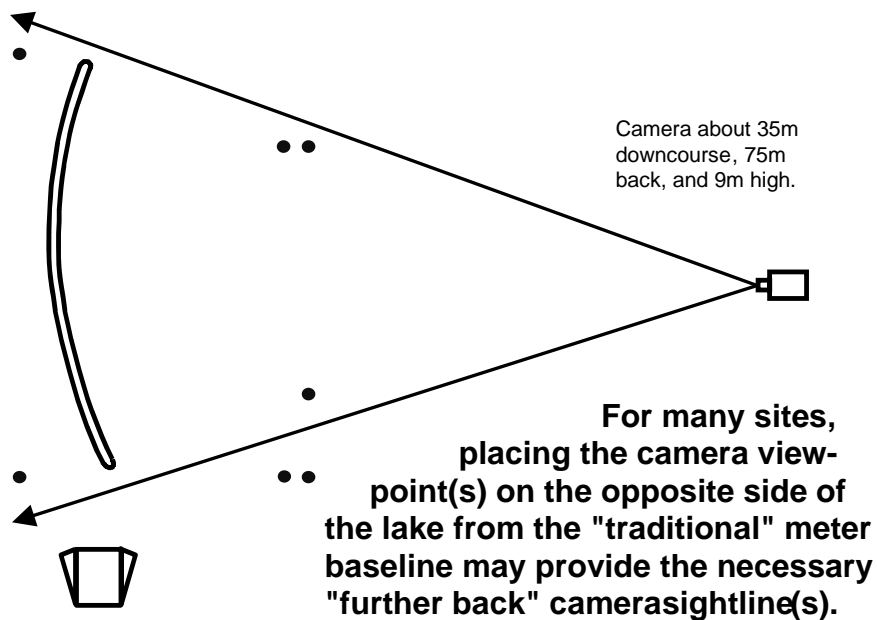
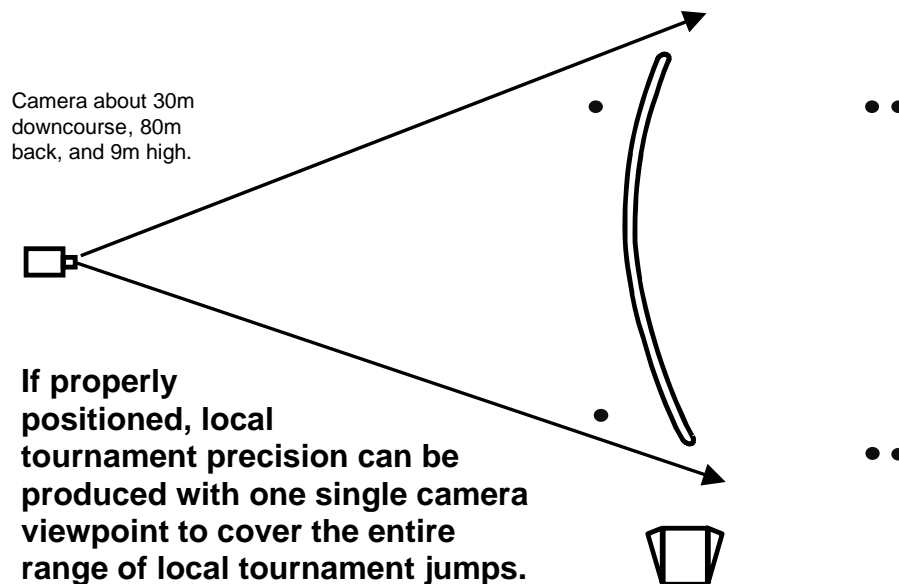

However, Record Capability precision will typically require either 2 or 3 cameras. In general, placing the cameras higher up and/or further away from the landing area will work better than closer in or lower down. Exactly where



# American Water Ski Association

## TECHNICAL CONTROLLERS' HANDBOOK

Revised 2007

Contributions By: Merle Vasbinder, Tom Dusin, Gene Davis, Dave Clark, Ed Brazil and others.

the cameras are positioned, and how the reference grids need to be set up, depends on how much room is available on the site, and what the lay of the land is like. Six alternative recommended layouts are presented on the following three pages, each of which is capable of meeting the most demanding Class "R" precision.

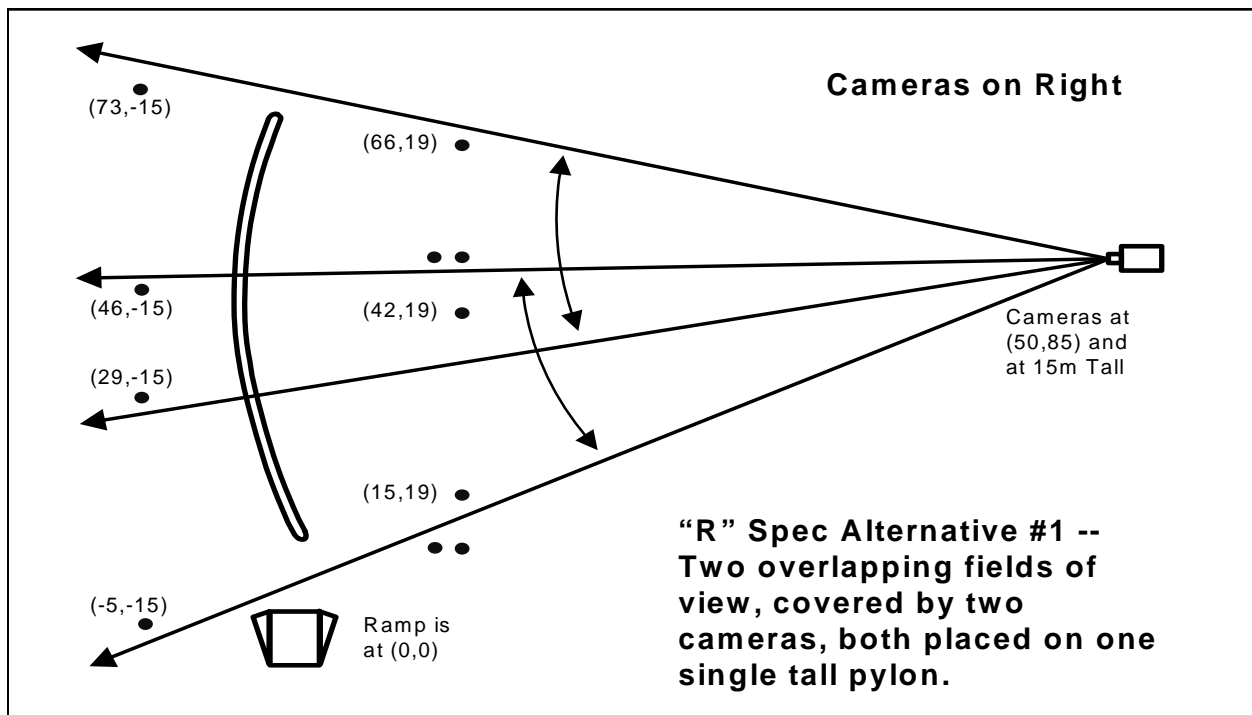
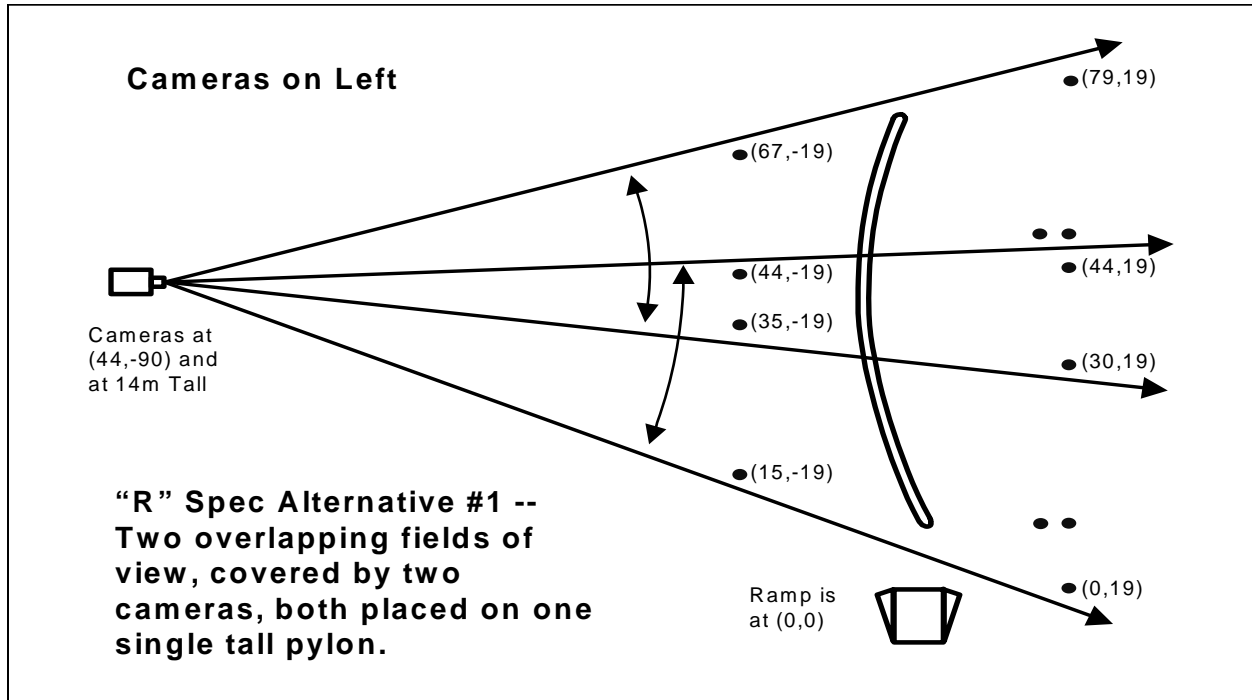



# American Water Ski Association

## TECHNICAL CONTROLLERS' HANDBOOK

Revised 2007

Contributions By: Merle Vasbinder, Tom Dusin, Gene Davis, Dave Clark, Ed Brazil and others.

### Cameras on Left

Cameras at (50,-65) and at 10m Tall

Cameras at (28,-65) and at 9m Tall

**“R” Spec Alternative #2 --  
Two overlapping fields of view, covered by two cameras, each on its own separate pole.**

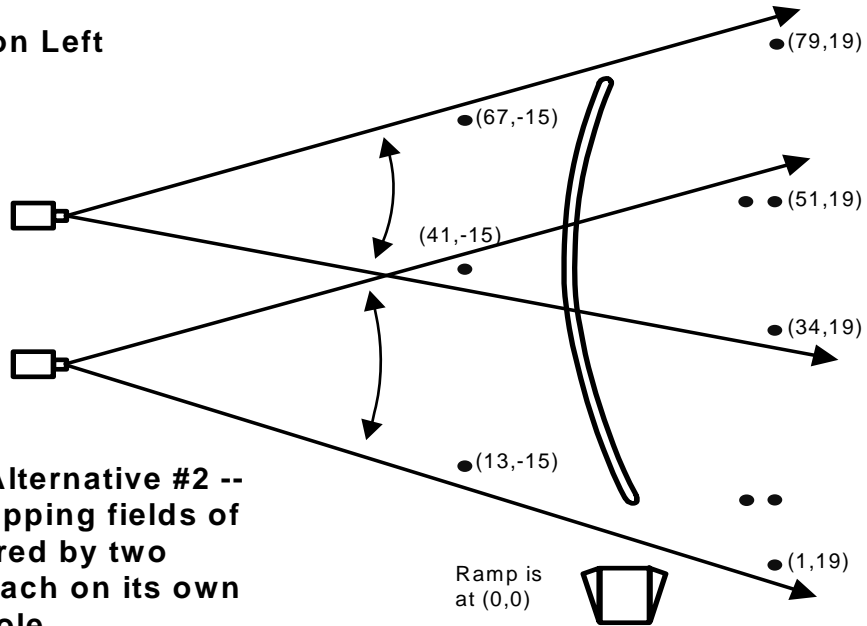

### Cameras on Right

Camera 2 at (58,60) and at 9m Tall

Camera 1 at (38,60) and at 11m Tall

**“R” Spec Alternative #2 --  
Two overlapping fields of view, covered by two cameras, each on its own separate pole.**

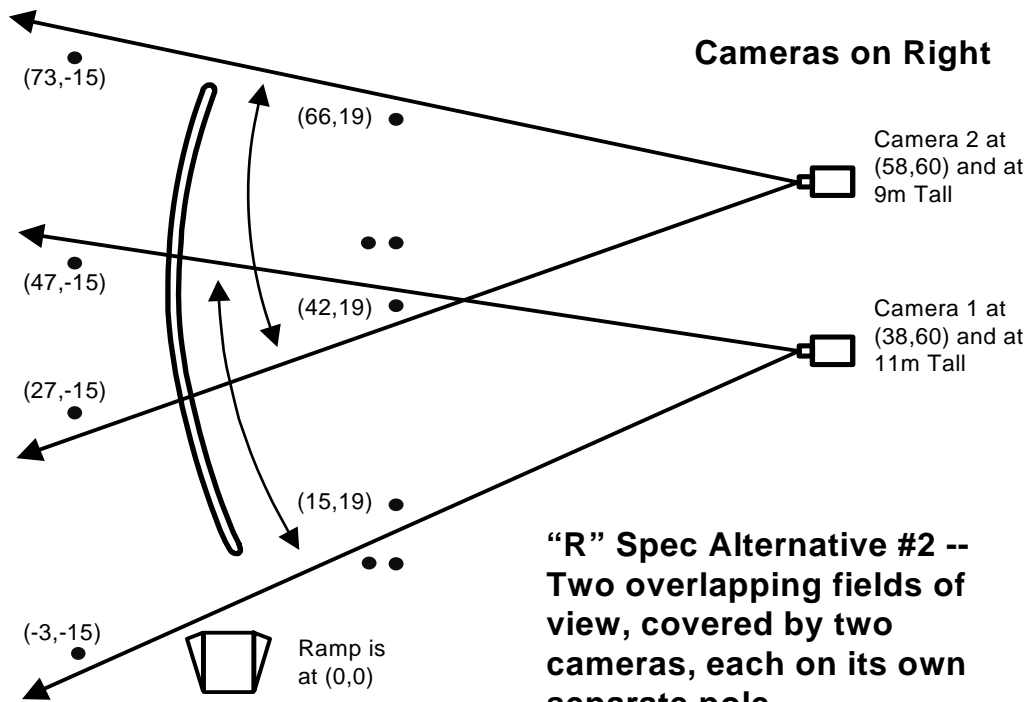



# American Water Ski Association

## TECHNICAL CONTROLLERS' HANDBOOK

Revised 2007

Contributions By: Merle Vashbinder, Tom Dusin, Gene Davis, Dave Clark, Ed Brazil and others.

### Cameras on Left

Camera 3 at (57,-45) and at 6m Tall

Camera 2 at (34,-45) and at 6m Tall

Camera 1 at (20,-45) and at 6m Tall

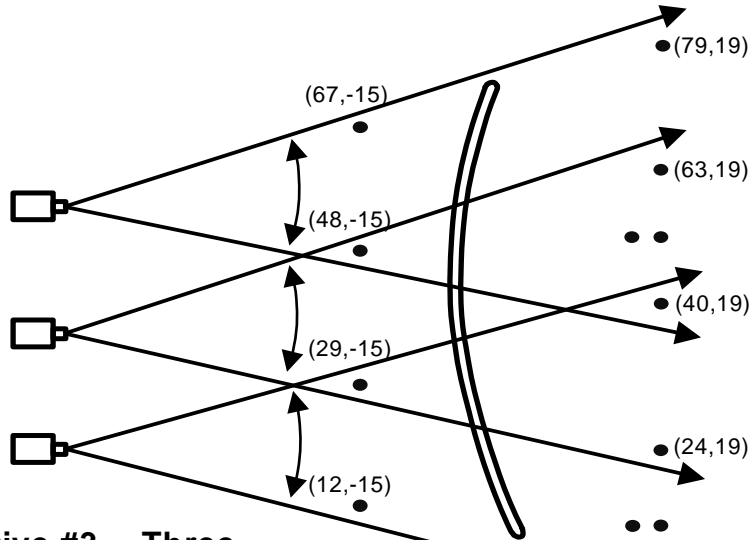

**“R” Spec Alternative #3 -- Three overlapping fields of view, covered by three cameras, each on its own separate pole.**

Ramp is at (0,0)

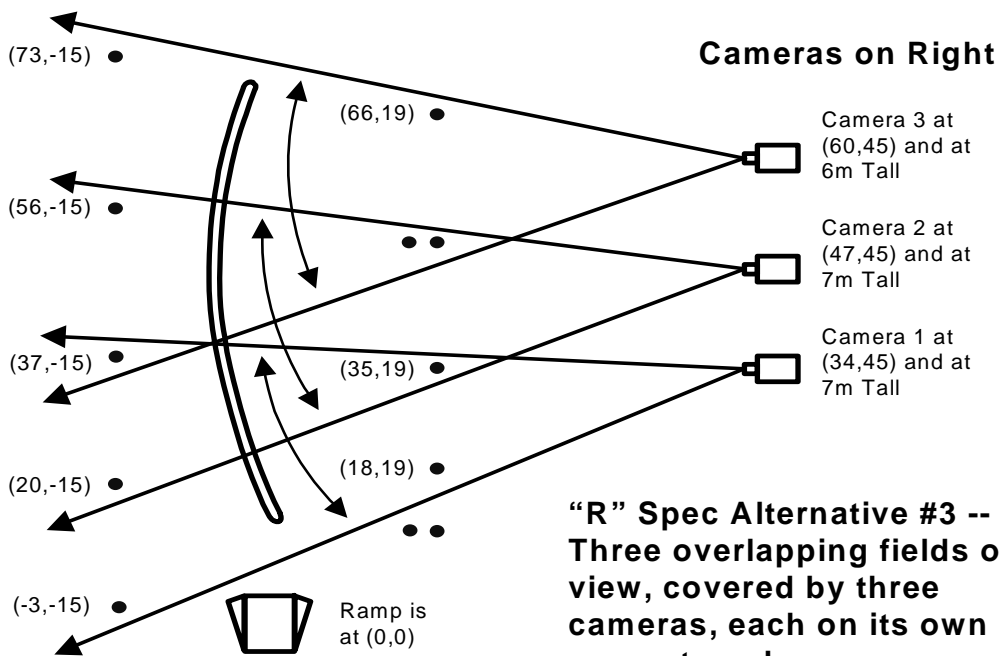

**“R” Spec Alternative #3 -- Three overlapping fields of view, covered by three cameras, each on its own separate pole.**

Ramp is at (0,0)





# American Water Ski Association

## TECHNICAL CONTROLLERS' HANDBOOK

Revised 2007

Contributions By: Merle Vashbinder, Tom Dusin, Gene Davis, Dave Clark, Ed Brazil and others.

Examples: VJVIEW16 "View Planning" analysis spreadsheet. Original proposed view at the top of the page fails in a few ways, while the revised view presented below that no longer shows any such failures.

**Originally proposed view** – note the flags shown with the grid height values, and on the sensitivity values at the longest end of the measurement zone. The camera is too low and too far towards the short end of the measurement zone.

Corson Video Jump Measurement System -- View Analysis Ver 1.6 03/01

Horiz Scrn Resolution	Min	Max	(F5) to A120 for Instructions & Notes						
(Pixels): 640	10	50	Intended Operating Distance Range (meters)						
	0	0	Widened? (see notes if not zeroes here)						
1-Pixel Movemt	10	50	Adjusted Operating Distance Range (meters)						
Test Std: 0.20	33	164	Adjusted Operating Distance Range (feet)						
Water Surface Locations of Grid & Camera	Up-Dn Crs	Acrc Crs	Screen Coordinates -X-	TWIP Angles -Y-	Vertx (deg)	Projctd onto Video	dimen- sions of Ref Grid	K	
Upper Left	51	19	2629	3977	159.97	High:	Left	595	###
Lower Left	43	-19	897	4572	20.72		Right	680	###
Upper Right	10	19	8642	4088	28.24	Wide:	Far	6014	0
Lower Right	15	-19	7318	4768	151.08		Near	6421	0
Camera Viewpnt	10	-77	Camera Angles: Pan		14.7	Tilt	-2.4	0	
Camera Elevation:		7	(Degrees) Field of View Width				29.3	0	
Selected Locations in the Jump Landing Zone	Up-Dn Crs	Acrc Crs	Horizontal Move			Vertical Move			K
			Up-Dn	Acrc	Dist	Up-Dn	Acrc	Dist	0
	-X-	-Y-	d(X)	d(Y)	d(D)	d(X)	d(Y)	d(D)	K
Long Jump 90%	50	-6.0	0.078	-0.020	0.080	0.463	0.823	0.369	###
Med-Long 70%	40	-6.0	0.076	-0.020	0.078	0.336	0.796	0.223	###
Med Jump 50%	30	-6.0	0.073	-0.019	0.075	0.217	0.770	0.072	0
Short-Med 30%	20	-2.0	0.074	-0.020	0.076	0.111	0.828	0.045	0

**Revised proposed view** – camera has been moved downcourse to a more centered location, and raised to a somewhat more elevated position overlooking the landing area. This cures all of the flags, and will result in acceptable precision.

Corson Video Jump Measurement System -- View Analysis Ver 1.6 03/01

Horiz Scrn Resolution	Min	Max	(F5) to A120 for Instructions & Notes						
(Pixels): 640	10	50	Intended Operating Distance Range (meters)						
	0	0	Widened? (see notes if not zeroes here)						
1-Pixel Movemt	10	50	Adjusted Operating Distance Range (meters)						
Test Std: 0.20	33	164	Adjusted Operating Distance Range (feet)						
Water Surface Locations of Grid & Camera	Up-Dn Crs	Acrc Crs	Screen Coordinates -X-	TWIP Angles -Y-	Vertx (deg)	Projctd onto Video	dimen- sions of Ref Grid	K	
Upper Left	51	19	1983	3948	111.80	High:	Left	859	0
Lower Left	43	-19	1635	4807	68.38		Right	884	0
Upper Right	10	19	8089	3977	115.71	Wide:	Far	6105	0
Lower Right	15	-19	8509	4861	64.12		Near	6874	0
Camera Viewpnt	27	-77	Camera Angles: Pan		2.9	Tilt	-3.9	0	
Camera Elevation:		9	(Degrees) Field of View Width				29.9	0	
Selected Locations in the Jump Landing Zone	Up-Dn Crs	Acrc Crs	Horizontal Move			Vertical Move			K
			Up-Dn	Acrc	Dist	Up-Dn	Acrc	Dist	0
	-X-	-Y-	d(X)	d(Y)	d(D)	d(X)	d(Y)	d(D)	K
Long Jump 90%	50	-6.0	0.076	-0.004	0.076	0.194	0.602	0.125	0
Med-Long 70%	40	-6.0	0.075	-0.004	0.075	0.109	0.598	0.024	0
Med Jump 50%	30	-6.0	0.075	-0.004	0.074	0.025	0.594	-0.086	0
Short-Med 30%	20	-2.0	0.078	-0.004	0.078	-0.061	0.657	-0.115	0



# American Water Ski Association

## TECHNICAL CONTROLLERS' HANDBOOK

Revised 2007

Contributions By: Merle Vasbinder, Tom Dusin, Gene Davis, Dave Clark, Ed Brazil and others.

### Video Reference Grid Coordinates from Manual Measurements. Measurement Recording Form

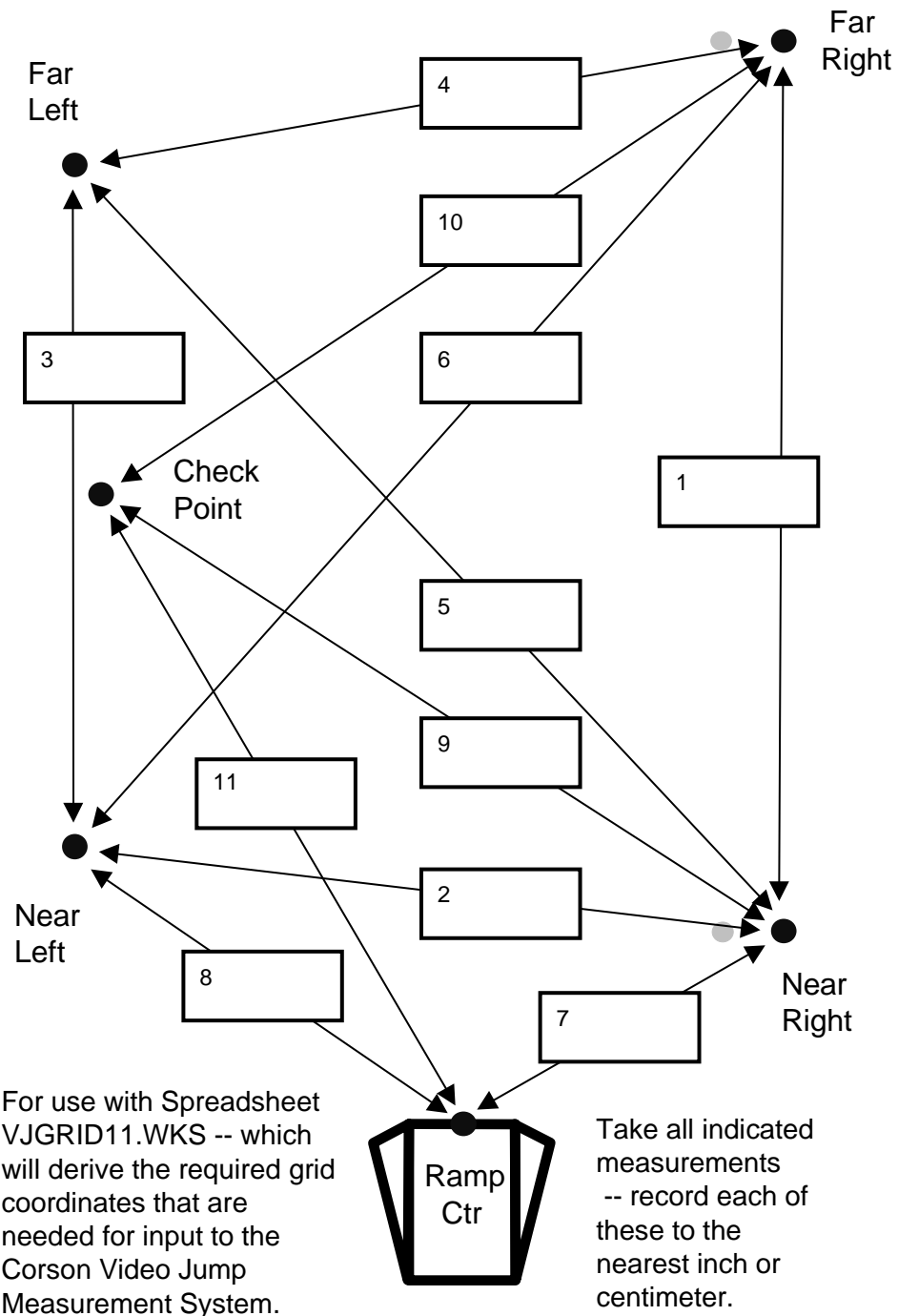





# American Water Ski Association

## TECHNICAL CONTROLLERS' HANDBOOK

Revised 2007

Contributions By: Merle Vasbinder, Tom Dusin, Gene Davis, Dave Clark, Ed Brazil and others.

## Sample of Manual Measurements

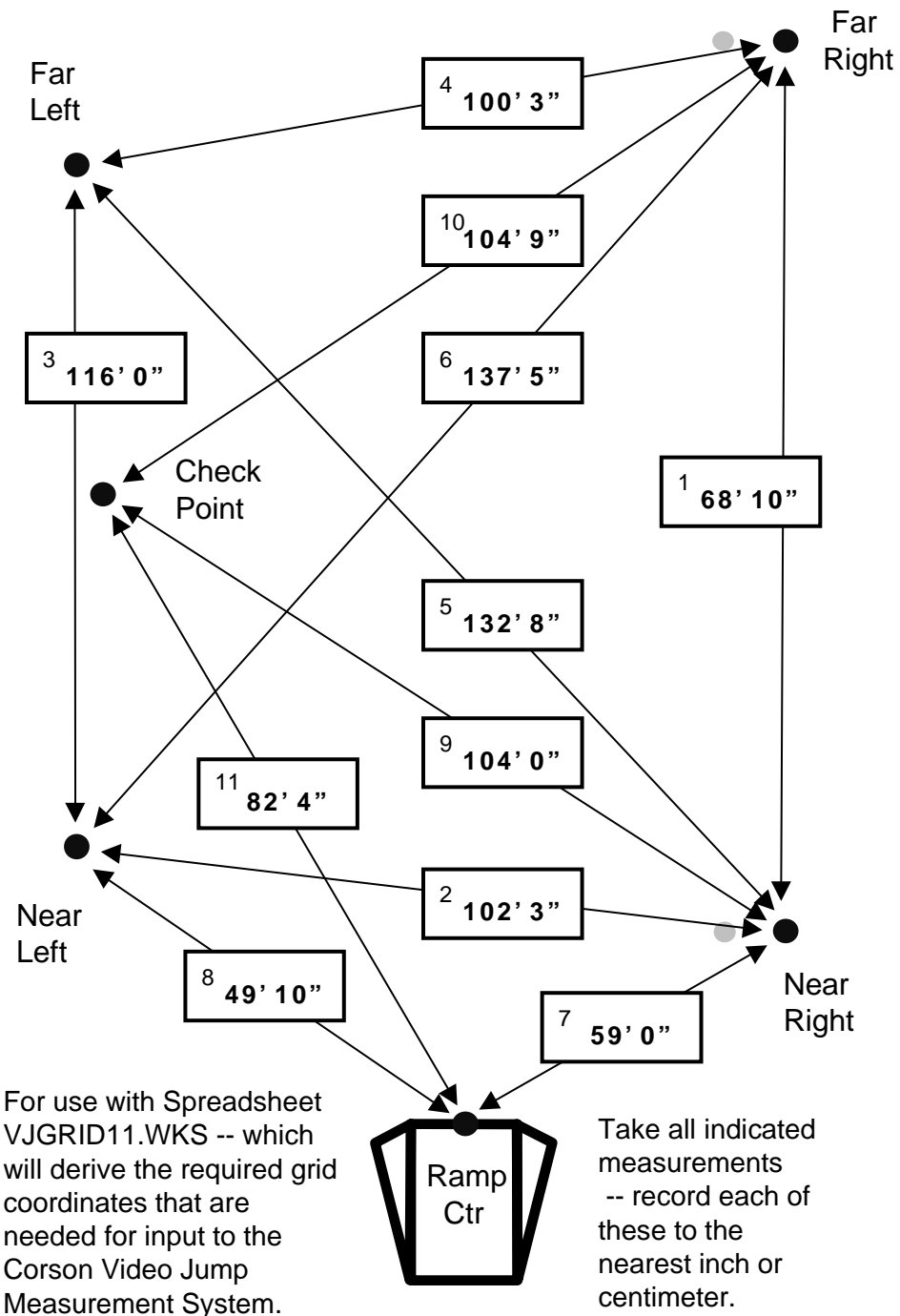



# American Water Ski Association

## TECHNICAL CONTROLLERS' HANDBOOK

Revised 2007

Contributions By: Merle Vasbinder, Tom Dusin, Gene Davis, Dave Clark, Ed Brazil and others.

Corson Video Jump System -- Reference Grid Measurement Ver 1.1 03/01

Measur- ment	Between Points	Raw Measurements Feet	Inches	Meters		Use form in VJGRID11.DOC Instructions at cell A51
	1 NR - FR	<b>68</b>	<b>10</b>	20.98	OK	Site Description:
Grid	2 NR - NL	<b>102</b>	<b>3</b>	31.17		-----
Sides	3 NL - FL	<b>116</b>	<b>0</b>	35.36	0	(Demonstration Sample)
	4 FR - FL	<b>100</b>	<b>3</b>	30.56		

Diag- onals	5 NR - FL	<b>132</b>	<b>8</b>	40.44		Date Measurements were Taken: (Enter Date Here)
	6 NL - FR	<b>137</b>	<b>5</b>	41.88		
	7 NR-Ramp	<b>59</b>	<b>0</b>	17.98		Measurement Key Diagram:
	8 NL-Ramp	<b>49</b>	<b>10</b>	15.19		

Check Pt	9 NR - CP	<b>104</b>	<b>0</b>	31.70		FL ----- 4 ----- FR
	10 FR - CP	<b>104</b>	<b>9</b>	31.93	0	\ 5 / /   ^
	11 Ramp-CP	<b>82</b>	<b>4</b>	25.10		\ 10 /

Key	Description	Derived Coords				
--	-----	--X--	--Y--	For Local		
FR	Far Right	<b>30.92</b>	<b>-14.99</b>	Tournament		
FL	Far Left	<b>37.14</b>	<b>14.93</b>	Use only.		
NR	Near Right	<b>9.94</b>	<b>-14.99</b>	** NOT **		
NL	Near Left	<b>1.76</b>	<b>15.09</b>	Approved	NL ----- 2 ----- NR	
Ramp	Ramp Center	0.00	0.00	for Record		
CP	Check Point	<b>20.08</b>	<b>15.04</b>	Capability	\ 8 \ 7 /	
				Purposes!		

Validity Checks:	Dist	Error	Calculated on:		Boat
-----	-----	-----	-----		Path
Derived NL - FL	35.3778	0.02	February, 2002		
Derived Ramp-CP	25.0889	0.01			

The report above is a reproduction of the VJGRID11 spreadsheet, which calculates CVJ reference point coordinates from manual measurements. The actual input section near the top is highlighted in bold. Note that these measurements are keyed to the 11 numbered boxes on the data recording form. The data in this example are the actual measurements from the completed data recording form that appears on the preceding page. Note that the raw measurements can be collected and input as either feet/inches, or as metric. But all coordinate results are in metric, as required by the CVJ programs.

The derived coordinates of the reference buoys and check point are then presented near the bottom. The values in that section are also shown in bold here. These are the values that need to be entered into the "Surveyed X and Y" Coordinate boxes in the grid setup screen of the CVJ measurement program.



# American Water Ski Association

## TECHNICAL CONTROLLERS' HANDBOOK

Revised 2007

Contributions By: Merle Vasbinder, Tom Dusin, Gene Davis, Dave Clark, Ed Brazil and others.

As a validity check, this spreadsheet also calculates derived lengths for the NL-FL and Ramp-CP distances, from the other inputs, and compares those to the actual measure lengths of these two segments. These check values appear at the lower left corner, and the "error" numbers are the differences between the actual and derived lengths. Ok as long as these are no large than about 0.15 meters (15cm or about 6 inches).

### **Additional Equipment**

Backup devices for the video include traditional video recorders (VCR) and more recently digital recorders such as RePlay TV, TIVO or CCTV digital recording devices. The typical analog video signal from the jump video cameras are connected via COAX cable or wireless transmitters to the recording device and the output can be input directly to the computer or split to enable simultaneous signals to two or more computers.

### **4) Trick requirements**

Setting up the trick course is not a difficult challenge: throw three buoys in the lake at approximately the point you want to start on each end. Seriously, though you should make sure that judges and the timer as well as the skier can easily see the starting point and that the trick course is long enough for the "high speed" tricker (22-24 mph) to get a 20-second run in without having to turn or run up on the bank. Another point that must be considered is the approach to the trick course. Is the initial leg long enough to adequately set the speed? The rule book specifies the color of the trick course buoys. The first one must be yellow and then orange or red. International rules for class "L" and "R" also include a green buoy placed 50 meters before the yellow "may start" buoy. The tolerance on the distance between the two set of buoys is great enough so that even the most casual measurement should keep them within tolerance. If other events are conducted on the same lake, or in the same area, ensure that buoys from other event courses do not interfere with the trick course. Ask the Lake Owner or representative about the lake bottom contour to ensure the boat path is over a reasonably even surface and is deep enough; communicate with the chief boat driver and LOC to determine the best distance offshore for the path.



# American Water Ski Association

## TECHNICAL CONTROLLERS' HANDBOOK

Revised 2007

Contributions By: Merle Vasbinder, Tom Dusin, Gene Davis, Dave Clark, Ed Brazil and others.

### Official Trick Course

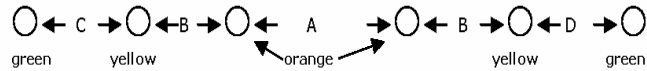

	<u>Dimension</u>	<u>Tolerance</u>	<u>Lower</u>	<u>Upper</u>
A	175 m (574' 2")	±10%	157.5 m (516' 9")	192.5 m (631' 6")
B	15 m (49' 2½")	±10%	13.5 m (44' 3½")	16.5 m (54' 1½")
C	50 m (164' ½")	± 10%	45 m (147' 7½")	55 m (180' 5½")

*An Optional green buoy marked by dimension "C" 50 meters prior to the Yellow buoys*

### Trick Speed Calibration Times

Times for speedometer calibration at trick speeds are for the speed indicated from the slalom course entry gates to the third buoy (109 m).

<u>Mph</u>	<u>Kph</u>	<u>Ideal</u>	<u>Tolerance</u>
11	17.7	22.17	21.20-23.33
12	19.3	20.32	19.51-21.20
13	20.9	18.76	18.06-19.51
14	22.5	17.42	16.82-18.06
15	24.1	16.25	15.73-16.82
16	25.8	15.24	14.78-15.73
17	27.4	14.34	13.93-14.78
18	29.0	13.55	13.18-13.93
19	30.6	12.83	12.50-13.18
20	32.2	12.19	11.89-12.50
21	33.8	11.61	11.34-11.89



# American Water Ski Association

## TECHNICAL CONTROLLERS' HANDBOOK

Revised 2007

Contributions By: Merle Vasbinder, Tom Dusin, Gene Davis, Dave Clark, Ed Brazil and others.

### **Trick Judges Towers**

The trick judging towers should be 3 meters (10 feet) above the water level and the entire tricking area must be visible from each tower or judging area. If multiple towers are to be used, insure that the distance between them is not so great as to cause the judges to have different views of the tricker at any point in the run. Too great a distance can also cause timing difficulties because of the speed at which sound travels. Verify that there are no objects which will obstruct the view of the judges. If the tournament is to be televised, check with the TV personnel to see where their cameras will be placed, since they may be put into place after you have already checked the area. For Class C tournaments, towers are not an absolute requirement, but elevated judging positions make the task much easier and generally produce better results. Also, ensure that there is an adequate place for videos to be taken, where the camera has the same approximate view as the judges. For record tournaments, ALL trick runs must be video taped, so make sure you have this aspect covered. If possible, have 110-volt electricity is available for the video equipment. This saves lots of battery swaps for a long tournament with lots of tricks. This electrical supply may also be used for the trick timing device. The trick timing device should be located approximately at mid course, and midway between the judges, so that delay in sound travel does not cause the judges to hear the horn at different times.

### **Boat video**

Both AWSA and IWSF allow the replacement of a boat judge by a camera operator; the duties of the boat judge are transferred to the boat driver. The video signal can be used for television media purposes or for judging of the trick run. When used for judging the video signal will be transmitted to a shore location by a wireless transmitter; it is recommended that both video and audio be utilized to record the skier identity with the video images. When judging the run by the method; the availability of immediate payback exists with a reduction from 5 to 3 judges which is allowed in both rules standards. The judging area should be set up with multiple viewing monitors or a projection of sufficient size to allow adequate separation of the judges. Multiple transmitters can be used on the same frequency; instruct the boat operators to turn off the transmitter power when they are not driving the current active competitor. Be aware that most wireless transmitters operate in the 900 – 2.4 GHz band range. Experience has shown that 2.4 GHz radio waves “bounce” off the surface to the water causing poor quality transmission. Mounting the receiver low near the water surface minimizes the effect and improves reception.

### **Video Frame Timing**

IWSF rule 15.12 requires the use of video frame timing. Two systems are currently approved: Corson and Botcher. The video camera can be located on shore with the same approximate view as the shore judges or transmitted from the boat with wireless transmitters. The Corson program is available for download from the AWSA website. The program requires the same general computer and camera equipment as the video jump system.



# American Water Ski Association

## TECHNICAL CONTROLLERS' HANDBOOK

Revised 2007

Contributions By: Merle Vasbinder, Tom Dusin, Gene Davis, Dave Clark, Ed Brazil and others.

### Tow Ropes

Probably one of the most frustrating jobs of the TC is dealing with the tow ropes. The nature of the material from which they are made causes a good deal of stretching to take place, and coupling this with the multitude of splices found in the multi-colored slalom line makes the task of having a tow rope which is and remains the proper length nearly impossible. If the tow lines are new, if at all possible they should be used for a short time before measuring, to tighten the knots and eliminate the original stretching. One good solution is to have each of the tow lines used in practice the day before the tournament, and then measure them after they have had an opportunity to relax. Stretching ropes between vehicles does little good, and in most cases is a waste of time. If this system is the only alternative, thoroughly wet the ropes before stretching. If the ropes are not new, and have been in storage for any length of time, it is again best if they can be used for a short period of time before measuring to eliminate the shrinkage that occurs in storage. All ropes should be inspected very carefully for wear and tear and compliance with AWSA specifications. Look for broken strands, fraying around the splices, the length of the splices, and general wear in the take-off loop area. Also check the handle section attachment end for wear and fraying. When dealing with ropes of all types, if you will use a metric tape and metric measurements, you will find the task much easier. All of the standard measurements are listed in metric measure, and produce even measurements. If you insist on using English measurements, you will have to deal with a lot of fractions.

#### 8.04 Tow Lines

The Tournament Committee shall furnish tow lines constructed as in 8.04(c) below with the lines and handles meeting the following specifications:

- a) Weight per foot, maximum = 23 g/m (.250 oz.) Breaking Load, minimum = 817 kg (1,800 lbs.) Elongation at 115 kg (250 lbs.) tensile load,  $2.6\% \pm 0.4\%$  the gauge length shall be set at 5.5 kg (12 lbs.) tensile load

All measurements of tow lines shall be made under 20 kg (44 lbs.) tension for at least 30 seconds and shall be made between the following points, as applicable:

- (1) The centerline of that portion of the handle furthest from the attaching loop;
- (2) The inside surface of any attaching loop furthest from the handle;

Tow line measurements shall comply with the Tow Lines Dimension Chart in the Appendix.

- b) Splices at the bridle and loop end of the line shall be 15 cm (6") long minimum, and secured with tucks before and/or after the splice, knotted to prevent slippage.
- c) The tow lines must be made in two sections consisting of a single line 21.5 meters long (70' 6.5") and a handle section 1.5 meters long (4'11"). Two-piece lines must be provided by the Tournament Committee, and the 21.5meter section, which can be attached to the contestant's handle section by looping the lines together, must be made available. In addition, colored multi-section lines may be used if the Technical Committee has specifically approved their design and type.
- d) The handle or handle assembly shall be made of 2.5 cm - 2.8 cm (1" to 1.25") outside diameter material with no sharp edges or projections, and it is recommended that it shall float. The attaching ropes must in all cases go completely through the handle twice and must be attached so there is no possibility of movement between the rope and



# American Water Ski Association

## TECHNICAL CONTROLLERS' HANDBOOK

Revised 2007

Contributions By: Merle Vasbinder, Tom Dusin, Gene Davis, Dave Clark, Ed Brazil and others.

handle when in use. The recommended minimum certified "permanent set load" of the handle, as measured with a six-inch straight edge across the handle, shall not exceed .039 cm (0.015") at any point along the handle at a load of 408 kg (900 lbs.), applied at any rate greater than or equal to 272 kg (600 lbs.) per minute. The test load shall be applied at two points 9 cm (3.5") apart at the center of the handle with the ends of the handle supported at the rope holes. The two load points shall each have a radius of .635 cm (0.25") and the end support may be any support which shall bear positively at the rope holes. A manufacturer may furnish a handle-bridle combination which may not necessarily have double entry at rope attachment, but such design must be approved by the Technical Committee following assurance of quality control through testing that shows all other requirements, including minimum loads, are complied with.

- e) Class E, L and R events pulled with alternating ropes shall use lines of the same model and manufacturer.

### Slalom Lines

Slalom ropes are the most difficult to qualify for a tournament, especially the "rainbow" multicolored ropes. The best way to measure and adjust the rope is to anchor one end to something permanent, and if possible, attach the measuring tape to the same anchor. If you have a metric tape, use it, because the metric measurements are much easier to use. Care should be taken to check for the slalom switch section; since it needs to be removed to use the switch; remove the handle and attach the handle end to the fixture. Put the 2 meter point of the tape at the fixture and then pull out both tape and tow line. Doing this should put the proper metric measurements opposite the loops in the line and you can check and adjust each loop as necessary. Remember, you measure to the inside of the end of the loop closest to the tow boat. Do not measure with the handle section installed, since different handle sections will be used during the tournament. Also remember, the line must be under 20 kg (44 lbs) tension for thirty (30) seconds when the measurements are taken. A small spring fishing scale which measures to 50 lbs can be obtained at most hardware stores, and will do the job nicely.

They are relatively expensive (\$25-30), but are easier to use than weights. Make an initial check of the rope to see if it is worth working with. If any of the loops are more than the allowable tolerance short in a multi-segment type line, you might as well throw the rope out and get another one, since there is practically nothing you can do to lengthen a rope unless you splice in another piece, and that generally does not produce a satisfactory solution. Before beginning any shortening procedures, check to see that a 10.25m loop is installed if that is going to be a requirement in your tournament. Many ropes come without this loop, and if it must be installed, affect the overall length of the rope.

If the loops are uniformly long, you can thread a scrap piece of ski rope into the portion of the rope beyond the last takeoff loop and that will shorten the overall length. As a general rule of thumb, approximately 20 inches of rope stuffed into the line will shorten it one inch. When stuffing rope pieces into a line, be sure and cut the ends at an angle to lessen the stress rise created by a straight cut. If the excessive length is not uniform, then the adjusting pieces will have to be stuffed into the individual sections that need to be shortened. Remember, though, shortening the length between two takeoff loops will shorten the remaining rope beyond the point at which the adjustment is made. When using a new rope (one that has only been used a short time for



# American Water Ski Association

## TECHNICAL CONTROLLERS' HANDBOOK

Revised 2007

Contributions By: Merle Vasbinder, Tom Dusin, Gene Davis, Dave Clark, Ed Brazil and others.

stretching), if you start out with each segment about five (5) cm, (2 in), short, then the rope will probably "grow" to about the correct length. If you begin skiing with a rope any on the long side of tolerance at all, after about an hour's use it will probably be out of tolerance long at lengths of 13 meters or less. Also while you are checking the rope ensure that the connection knots on multi-segment ropes are in the form of a half hitch instead of a square knot. This will prevent the rope from "popping" when skiers make strong pulls. It is a good idea to check the slalom ropes that have been used each day, since it is frequently necessary to adjust them again after one or two days' use. If you will record the length of the rope while you are adjusting it, you can then use this information to complete the TC report.

Once you have measured and qualified a tow rope, find a way to mark it so that it can be identified. Putting a "duct tape tag" on the tow boat end of the rope works, or if you have permanent magic markers, you can put marks on the lighter colored section of the rope. One mark is rope one, two marks, rope two, etc. Wrapping the plastic ties that come around a rope works the same way as the magic marker. For normal record tournaments, three or four slalom ropes should be sufficient. If it is a three-round slalom tournament, more may be necessary. Work with your tow boat crews to watch carefully for knots and get them out before they become set. Once they are set, the rope becomes a practice line. Another hint for extending the life of a tow rope is not using a slip knot on the pylon. The new pylons are such that you can slip the loop over the pylon and it will stay, especially if you put the anti-recoil tube on top of it.

### **Jump lines**

Jump ropes are much easier to deal with for two reasons. One is that they do not have all of the splices to stretch and give, and the other is that they have a greater tolerance to work with. Most of the time you will not have to do much to a jump rope other than to measure and mark it. If adjustment is necessary, then use the same procedure as with slalom ropes. Even though the record book permits variation of thirty (25) cm. (10 inches) for record tournaments, fifteen (15) cm. (6 inches) sounds like a better figure.





# American Water Ski Association

## TECHNICAL CONTROLLERS' HANDBOOK

Revised 2007

Contributions By: Merle Vasbinder, Tom Dusin, Gene Davis, Dave Clark, Ed Brazil and others.

### Handle Sections

If a handle measuring device is available, use it. Otherwise, use the same system used for checking the ropes. It is probably best to adjust each tournament handle section to exactly 1.5 m long. Note that the tolerance for tournament supplied handles is +/- 2.5 cm. (1 inch). Also check the tournament supplied handle for being square, i.e., the grip forms a 90 degree angle with the tow section. Check that the rubber grip on the handle is secure, and does not give or slip when twisted. Also check the length of the handle itself. The tournament supplied handle must be 11 inches (+/- 1) long. There is no limit to length on skier provided handles. The handle can easily be shortened by stuffing scrap rope into the rope portion of the section. If the section is too short, be careful about retying them. Make sure there is enough rope left beyond the knot to prevent slippage. The magic marker system or plastic tie system seems to work best for marking handle sections. Skiers tend not to like tags on handle sections and will frequently tear them off.

Checking the individual skiers' handle sections can present some real problems. If you can get the dock starter to do this it is the best solution; for class "E" events there is no requirement to secure the handle before skiing, class "L&R" requires the handle to remain in the custody of the dock starter at least three skiers in advance of the contestants turn. Some suggestions is to set up a handle checking device for the skiers to use themselves, and then randomly check individual handles, possibly even after the contestant has skied.

### Timing Devices

Stop watches have not been used in tournament water skiing for several years, the need for the TC to verify the accuracy of timing devices is all but obsolete. And the timing of the tow boat has become the territory of the drivers now days. You should be aware of the conditions that can effect timing however. Magnets used to trigger the cruise control (and timer) should be at the same relative depth below the buoys; about 1 foot. Magnet strength, when checked with the speed control device should be **within** a relative strength of 5-10 of each other. The polarities of magnets need to be oriented with similar poles up; and all boats should have the magnet pickups all facing the same direction. Again this task has in reality fallen to the chief boat driver, but at this time is still reported by the TC.

### Trick Timing Device

This also would be a good time to check the trick timing device. For record tournaments, "E, L & R" a computer based frame counter is used as the trick timing device and is recommended for "C" tournaments. Verify the accuracy of the frame counter by videoing a watch or stop watch and compare the computer counted time to the video of the stop watch. ***There have been reports of external USB capture devices shorting the time by over a second.***



# American Water Ski Association

## TECHNICAL CONTROLLERS' HANDBOOK

Revised 2007

Contributions By: Merle Vasbinder, Tom Dusin, Gene Davis, Dave Clark, Ed Brazil and others.

### **Video Trick Timer 2004** (Initial Documentation)

This document describes the Video Trick Timer 2004 program operation.

The intent of this redesign was to make the product more reliable by using commercial controls rather than shareware controls and to simplify its operation to make it more "user friendly".

The VTT04 consists of three basic screens as follows:

Setup  
Capture  
Timer

Menu Selections

View Log  
View Manual  
Exit

#### **View Log**

Each time a trick run is captured and processed through the timing screen, that information is recorded in this log. You can view any run or retime the run by selecting the desired run and then clicking the View button (or double-clicking the file) which will take you to the Timer Screen with the selected file loaded.

**View Manual** takes you to the screen you are now in; "Viewing the Manual".

**Exit** – Quit the program

Setup Screen Buttons and Controls

Proceed to Record Runs

This button takes you to the screen where you will record the trick run and operate the audible timer.

View Already Recorded Runs

This button takes you directly to the screen where you select the start of the trick run. From there you can load a run to view.

Save Video Files in this Directory

Type in the folder where you will save the captured video files

Import Skier Names Button

If you have an already existing list of all of the skier's names, you can import this into the program. Once that is done, you only have to select the name from a list rather than typing it as the skier has his turn. The list should be a plain text list with one name per line like this:

Jimmy Siemers  
Cory Pickos  
Nicolas Leforestier



# American Water Ski Association

## TECHNICAL CONTROLLERS' HANDBOOK

Revised 2007

Contributions By: Merle Vasbinder, Tom Dusin, Gene Davis, Dave Clark, Ed Brazil and others.

And so on. You might want to alphabetize it if it is a large list.

### **Enable Barefoot**

Checking the textbox sets the trick run time to 15 seconds for barefoot.

### **Show Configuration**

Clicking this button reveals all of the technical parameter settings for your video hardware. This will vary for each system.

The most important items to select here are the resolution which probably should be **320x240**, the compression method (Microsoft 1 or Indeo) and the frame rate. The frame rate must be 30 (25 for PAL) for an R tournament, 15 or higher for an L and 10 for normal or class C. You must set these parameters to some combination where during the capture process, you will not drop frames (the faster your computer, the better). Making the picture smaller or the capture slower may be required so that you do not lose frames. Losing frames should not affect the timing, ***but it might affect your ability to select the correct start frame if you drop frames at that point.***

Once all of these parameters have been set, you can hit the "Hide Configuration" button and should not need to access this screen again as all of the parameters are saved in the Registry on this individual computer.

### **Capture Screen**

When you enter the capture screen, the program first checks the name of the file that you will save the capture to. The name of the file is the skier's name followed by the pass number. If a file already exists for what you have set up, a warning will tell you, but not prevent you from saving the file. The Start Recording button will be highlighted. The idea is to start to record when the skier passes the 50m (green) "can't change the speed" buoy. The recording is set to run for 40 seconds. A countdown timer will show how much time is left. You can just let the capture process happen and take no further action on this screen. It will automatically switch to the Timer Screen when it is finished.

You can also use the Start Recording Menu to start recording. Just hit the ALT key to select the menu and then when you are ready to start hit the ENTER key.

There is a Start Trick Timer button. The function of this button is to tell the program where the skier starts. This will make it easier to position to the exact start point in the timer screen. It also activates a start horn and then in 20 seconds an ending horn. A 20 second timer countdown (15 for barefoot) is shown. If you press the Start Trick Timer button and there is less than 20 seconds left on the recording time, ***the file recording time will automatically be extended by 25 seconds from that point.***

To stop recording at any time, press the ESC key. Some examples might be if the skier falls or if the pass is over and you do not want to wait for the full 40 second time to end.

Pressing the ESC key or waiting until the recording time expires both have the same effect of switching to the timer screen.



# American Water Ski Association

## TECHNICAL CONTROLLERS' HANDBOOK

Revised 2007

Contributions By: Merle Vasbinder, Tom Dusin, Gene Davis, Dave Clark, Ed Brazil and others.

Status boxes show the number of frames saved and the number of frames dropped. The initial configuration should be set so that no frames are dropped.

You can also go back to setup or on to the timer if you decide not to record the run.

Pressing the Select button brings up the list of skiers to select from if one had been loaded in. Just double-click on the skier you want and that name will be loaded in. You may also type in a name.

### Timer Screen

If you get to the Timer Screen via the recording process, the recorded file will be loaded. If you used the "Start Trick Timer" function, the video will be positioned at the point where you pressed the button. If you did not use the start timer function, the video will be positioned seven seconds after the start of the run, which hopefully will be close.

Use the slider, arrow buttons, or keyboard arrow keys to move to the exact start frame. Press the "Play before Start" button to play for 2 seconds up to the point you selected. Do this as much as required to ensure that your selection is correct. You can change the 2 second value if you want. You can also use the full screen by checking the option box that says "Play using full screen". You get back to the regular screen by pressing Escape. Once you are happy with the selection press the "Mark Displayed Frame" button this will set that frame as the start and the play the last 5 seconds of the run up to the end of the run so you can identify the last trick. You can also with the "Play to end, pause, continue" button, play past the end point as that may clarify what the last trick was. This process also locks in the start frame so that you can't change it. If you want to you can also use the full screen by checking the option box that says "Play using full screen". You get back to the regular screen by pressing Escape.

The normal process would then be to go back to the Recording Screen using the button.

You can also get to the timer screen directly to measure existing files. Use the selection button to pick a file to view or measure. When you select a file that already has been measured, you will receive a warning that tells you what the measured start frame already measured was.

You can also access the log file which will allow you to view the runs that you have already captured and measured. The status bar underneath the video player shows you the frame counts.



# American Water Ski Association

## TECHNICAL CONTROLLERS' HANDBOOK

Revised 2007

Contributions By: Merle Vasbinder, Tom Dusin, Gene Davis, Dave Clark, Ed Brazil and others.

### **Communications**

Good communications is one of the keys to a smoothly running tournament, and enough cannot be said about the need to be prepared for the unexpected. During your travels about the site, take a radio with you to ensure that it will communicate with the main judging area from all locations. If not, either correct the problem or make sure that the chief judge is aware of the deficiencies. Establish in advance communications failure procedures and make sure they will work. If hard-wired systems are to be used, ensure that there is a backup system that can be used if the system goes down. Also, check the system in advance to see that it operates. While working with communications systems, determine what effect precipitation will have on them, and establish procedures for providing the necessary protection. Also determine who is to be responsible for correcting communication problems.

Communication systems have caused problems with automatic timing systems. During your check out of the communications, determine what effect, if any, the radios will have on automatic timing systems. The interference problem appears to be more pronounced when using high powered business channel radio's; FRS or Family Channel Radio's in recent years have proven to be a very reliable and inexpensive communication tool which rarely affect the timing and speed control systems in use today.

### **During the Tournament**

At the start of the day for slalom, supply the starting dock with at least three ropes including long line sections, shock tubes and a tournament handle. Ensure you have aligned the end course video camera and turned on a radio for the audio track, start or arranged for someone else to start the video recorder, check and set the recording speed (EP) and label the tape. Do a visual of the course buoys to ensure they have maintained the correct height. If a record is achieved during the event, collect the rope and skier handle for measurement. Rotate the extra rope in while you wait the required 30 minutes for the measurement. During the day rotate ropes in and out to ensure they do not stretch out of tolerance. This is a good task for an aspiring TC, checking and adjusting the ropes as necessary. If video equipment is used for gates, check alignment and zoom and start tapes.

For Jump, much more has to be setup; video measurement requires a video tape for each grid VCR. The camera's are powered on, the view is checked, the VCR and computers are turned on the video capture program is started and if you are using versions from before 2005 the measurement program is started.



# American Water Ski Association

## TECHNICAL CONTROLLERS' HANDBOOK

Revised 2007

Contributions By: Merle Vasbinder, Tom Dusin, Gene Davis, Dave Clark, Ed Brazil and others.



## AWSA RECORD FORM

### Application for World and / or National Record

#### Attention Chief Judge:

This application must be completed within 21 Days of the completion of the event and sent, with all necessary supporting data, including vhs video tapes Surveys & Dossiers to:

- the AWSA Headquarters
- the Chairman of the IWSF Tournament Council ( if it is a World record )
- the Chairman of the AWSA Technical Committee (Notify the Chairman with in 10 days)

#### Description of the performance:

Division:  Event:  Performance:

Date of performance:  Round:

Tournament Name:  Sanction #:

Location:

#### Identification of the Skier:

Name:  Birth date:

Address:  Membership #:

City, St Zip:

Boat Info:

Speed  
Control:



# American Water Ski Association

## TECHNICAL CONTROLLERS' HANDBOOK

Revised 2007

Contributions By: Merle Vasbinder, Tom Dusin, Gene Davis, Dave Clark, Ed Brazil and others.

Make &  
Model:

Manufacture:

Year:

Software  
Ver. :

### Official's statements:

" To the best of our knowledge, all current AWSA rules and record specifications ( except as noted ) were followed, and the tournament at which this record performance was accomplished was conducted according to the record capability standards. We therefore recommend acceptance of the enclosed record."

### CHIEF OFFICIALS:

Position	Name	E-Mail	Phone #	Rating
Chief Judge:				
Tech Controller:				
Chief Scorer:				
Chief Driver:				

### EVENT OFFICIALS:

Boat Judge:				
Judge:				
Judge:				
Judge:				



# American Water Ski Association

## TECHNICAL CONTROLLERS' HANDBOOK

Revised 2007

Contributions By: Merle Vasbinder, Tom Dusin, Gene Davis, Dave Clark, Ed Brazil and others.

Judge:

--	--	--	--

Judge:

--	--	--	--

Driver:

--	--	--	--







# American Water Ski Association

## TECHNICAL CONTROLLERS' HANDBOOK

Revised 2007

Contributions By: Merle Vasbinder, Tom Dusin, Gene Davis, Dave Clark, Ed Brazil and others.

### 2. Ski

Does the ski qualify under W. Rule 10.03?

#### **Slalom Course:**

Include a copy of the survey with this application.

Date of the course survey:

Do the skier and gate buoys meet the requirements of W. Rule 14.06?

#### **End Course Video:**

Enclose the end course VHS Tape.



# American Water Ski Association

## TECHNICAL CONTROLLERS' HANDBOOK

Revised 2007

Contributions By: Merle Vasbinder, Tom Dusin, Gene Davis, Dave Clark, Ed Brazil and others.

### Trick Record Form

### TRICK RECORD DATA

**Note:** Attach to these form copies of the trick run submitted by the skier and of the judges' sheets. Judges must sign and date the reviewed Judges Sheets (Pink Sheets)

**Score:**

FIRST PASS

SECOND PASS

	Trick	Value
T1		
T2		
T3		
T4		
T5		
T6		
T7		
T8		
T9		
T10		
T11		
T12		
T13		
T14		
T15		
T16		
T17		
T18		
T19		
T20		
	TOTAL PASS 1	0

	Trick	Value
	TOTAL PASS 2	0

**TOTALS**



# American Water Ski Association

## TECHNICAL CONTROLLERS' HANDBOOK

Revised 2007

Contributions By: Merle Vasbinder, Tom Dusin, Gene Davis, Dave Clark, Ed Brazil and others.

First pass:	0
Second pass:	0
<b>SCORE :</b>	0

**Ski:**

Width:

Length:

Ratio W / L :

#DIV/0!

### Trick Course:

Do the course and the judges' tower meet the requirements of AWSA Rule 11.16(a)?

### Video Review:

Each judge must review the video tape (VHS) to ascertain that his submitted judge's sheet is correct.

The video will be viewed in regular speed.



# American Water Ski Association

## TECHNICAL CONTROLLERS' HANDBOOK

Revised 2007

Contributions By: Merle Vasbinder, Tom Dusin, Gene Davis, Dave Clark, Ed Brazil and others.

### Record Form for Video measurement

#### JUMP RECORD DATA

##### Calculation of the jump

**Distance:**  Feet  Meters

##### Timing ( in .01 seconds )

1st Segment:  seconds      2nd Segment:  seconds

Optional timing 2nd segment method used:

##### Video Jump

Manufacturer:

##### Test Buoy:

coordinates

X                      Y

survey

--	--

Video system

--	--

##### Grid System:

coordinates

X                      Y

Jump

--	--

Upper Left

--	--

Upper Right

--	--

Lower Left

--	--

Lower Right

--	--

##### Ramp check:

Measure again the height and length of the ramp before changing its position.



# American Water Ski Association

## TECHNICAL CONTROLLERS' HANDBOOK

Revised 2007

Contributions By: Merle Vasbinder, Tom Dusin, Gene Davis, Dave Clark, Ed Brazil and others.

Left side:	Height	<input type="text"/>	Length	<input type="text"/>	Ratio	#DIV/0!
Right side:	Height	<input type="text"/>	Length	<input type="text"/>	Ratio	#DIV/0!
Width of ramp:	Top	<input type="text"/>	Bottom	<input type="text"/>		

Maximum deviation from plane:

Diagonal string  
measurement

Center string measurement

### Equipment Check:

Note: wait at least 30 minutes after last use to measure the rope.

#### 1. Rope:

Length:

#### 2. Ski:

Does the ski qualify under W. Rule 10.03?

### Video and Files:

Enclose a copy of the video ( VHS ), a gif formatted file of the record jump, and all configuration and setup files appropriate for the system being used to allow independent verification.



# American Water Ski Association

## TECHNICAL CONTROLLERS' HANDBOOK

Revised 2007

Contributions By: Merle Vasbinder, Tom Dusin, Gene Davis, Dave Clark, Ed Brazil and others.

### Record form for metered measurement

#### A. Meter Data: record the meter readings of the landing point below.

	Meter A	Meter B	Meter C	Verified by:
Upper				
Lower				
Average	0	0	0	

#### B. Calculations:

1. Distance:  Feet  Meters

#### C. Meter Setup Data:

	Meter A	Meter B	Meter C
Angle to Jump from:			
Distance to Jump From:			
Angle to 15ET from:			
Angle from A to:			
Angle from B to:			
Angle from C to:			

Distance:	AB	<input type="text"/>	Distance L:	<input type="text"/>	
	BC	<input type="text"/>		Ramp Triangle Size:	<input type="text"/>
	AC	<input type="text"/>		15ET Triangle Size:	<input type="text"/>

#### Timing ( in .01 seconds )

1st Segment:  seconds      2nd Segment:  seconds

#### Ramp check:

Measure again the height and length of the ramp before changing its position.

Left side:	Height	<input type="text"/>	Length	<input type="text"/>	Ratio	#DIV/0!
Right side:	Height	<input type="text"/>	Length	<input type="text"/>	Ratio	#DIV/0!
Width of ramp:	Top	<input type="text"/>	Bottom	<input type="text"/>		

Maximum deviation from plane:

Diagonal string measurement



# American Water Ski Association

## TECHNICAL CONTROLLERS' HANDBOOK

Revised 2007

Contributions By: Merle Vasbinder, Tom Dusin, Gene Davis, Dave Clark, Ed Brazil and others.

Center string  
measurement

### Equipment Check:

Note: wait at least 30 minutes after last use to measure the rope.

#### 1. Rope:

Length:

#### 2. Ski:

Do the skis qualify under W. Rule 10.03?







# American Water Ski Association

## TECHNICAL CONTROLLERS' HANDBOOK

Revised 2007

Contributions By: Merle Vasbinder, Tom Dusin, Gene Davis, Dave Clark, Ed Brazil and others.

### Appendices

### Tow Line Dimensions

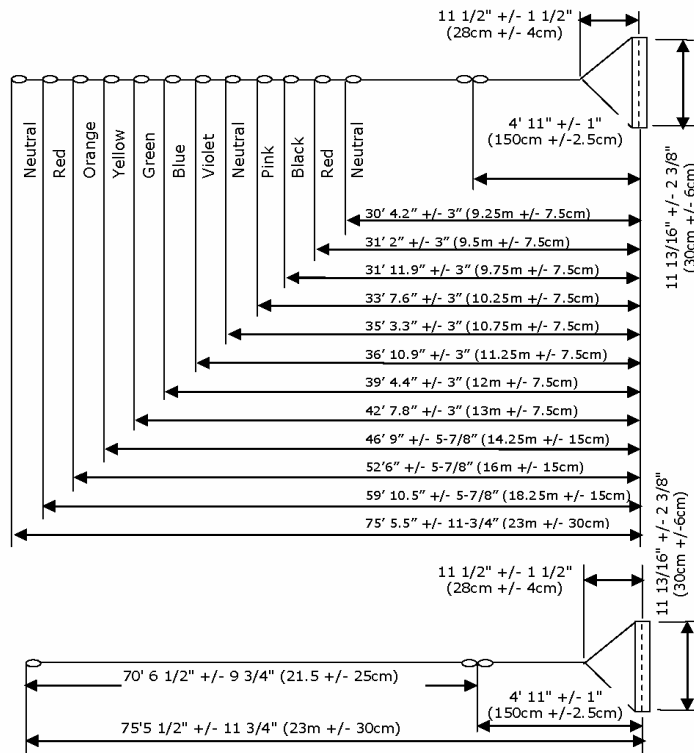

**Note:** For tournament-supplied handle sections, the bridle length shall be 150 cm  $\pm$  2.5 cm (4'11"  $\pm$  1") and the length of the handle shall be 30cm  $\pm$  6 cm (11-13/16"  $\pm$  2-3/8") (see diagram). For skier-supplied handles in the Slalom and Jumping events, the tolerance on the bridle length is + 2.5 cm/-10 cm (+1"/-4").

A Slalom Switch or other appliance may be used to attach the slalom towline to the pylon. When so used, that appliance shall be considered a part of the boat/pylon, may be from 0.47 to 0.51m in length, and with a recommended length of 0.50m. The measurements of ropes used with such appliances shall be 0.50m shorter than the values shown in this table.



# American Water Ski Association

## TECHNICAL CONTROLLERS' HANDBOOK

Revised 2007

Contributions By: Merle Vasbinder, Tom Dusin, Gene Davis, Dave Clark, Ed Brazil and others.

### Official Slalom Course

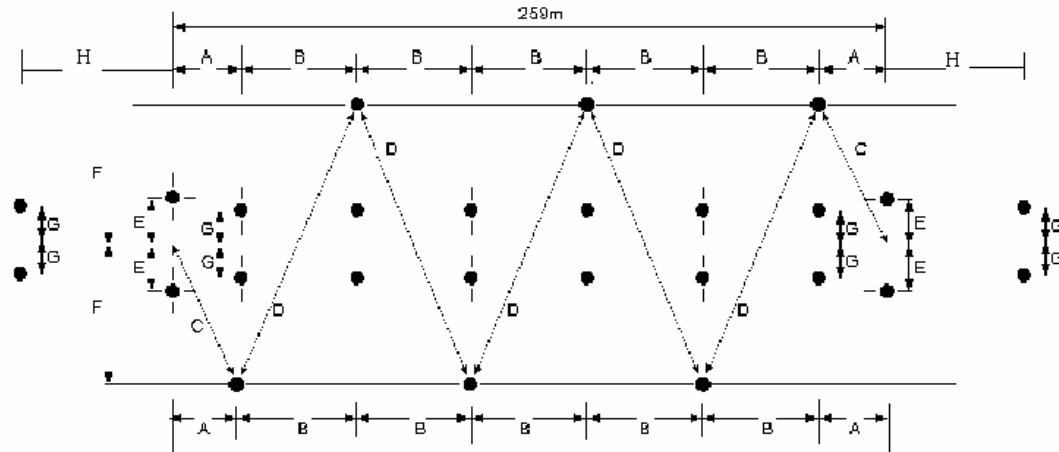

Dim	Metric			English					
	Actual	Minimum	Maximum	Actual	Minimum	Maximum	Actual	Minimum	Maximum
<b>OA</b>	259m	258.353m	259.648m	849'	8 <sup>7</sup> / <sub>8</sub> "	847'	7 <sup>3</sup> / <sub>8</sub> "	851'	10 <sup>3</sup> / <sub>8</sub> "
<b>A</b>	27m	26.865m	27.135m	88'	7"	88'	1 <sup>5</sup> / <sub>8</sub> "	89'	1/4"
<b>B</b>	41m	40.795m	41.205m	134'	6 <sup>1</sup> / <sub>8</sub> "	133'	10 <sup>1</sup> / <sub>8</sub> "	135'	2 1/4"
<b>C</b>	29.347m	29.2m	29.494m	96'	3 <sup>3</sup> / <sub>8</sub> "	95'	9 <sup>5</sup> / <sub>8</sub> "	96'	9 <sup>1</sup> / <sub>8</sub> "
<b>D</b>	47.011m	46.776m	47.246m	154'	2 3/4"	153'	5 <sup>3</sup> / <sub>8</sub> "	155'	1/8"
<b>E</b>	1.25m	1.188m	1.313m	4'	1 1/4"	3'	10 3/4"	4'	3 3/4"
<b>F</b>	11.5m	11.385m	11.616m	37'	8 3/4"	37'	4 1/4"	38'	1 <sup>3</sup> / <sub>8</sub> "
<b>G</b>	1.15m	1.035m	1.265m	3'	9 1/4"	3'	4 3/4"	4'	1 3/4"
<b>H</b>	55m	54.725m	55.275m	180'	5 <sup>3</sup> / <sub>8</sub> "	179'	6 1/2"	181'	4 1/4"
<b>Tolerances (±)</b>									
				1/4% on 259m		5% on E			
				1/2% on A,B,C,D,H		10% on G			
				1% on F					

At all Record Capability tournaments (E,L,R) including Regionals and Nationals, boat path alignment gates consisting of cylindrical buoys (green recommended) of a color contrasting to the official course buoys, and placed outside the official course at a distance of 55m (180' 5<sup>3</sup>/<sub>8</sub>" ) before the end and at either end and at the 1.15m (3' 9<sup>1</sup>/<sub>4</sub>" ) width of the interior boat guide buoys—are mandatory. Where practical, their use is recommended at all other events.



# American Water Ski Association

## TECHNICAL CONTROLLERS' HANDBOOK

Revised 2007

Contributions By: Merle Vasbinder, Tom Dusin, Gene Davis, Dave Clark, Ed Brazil and others.

### Official Jump Course Diagram

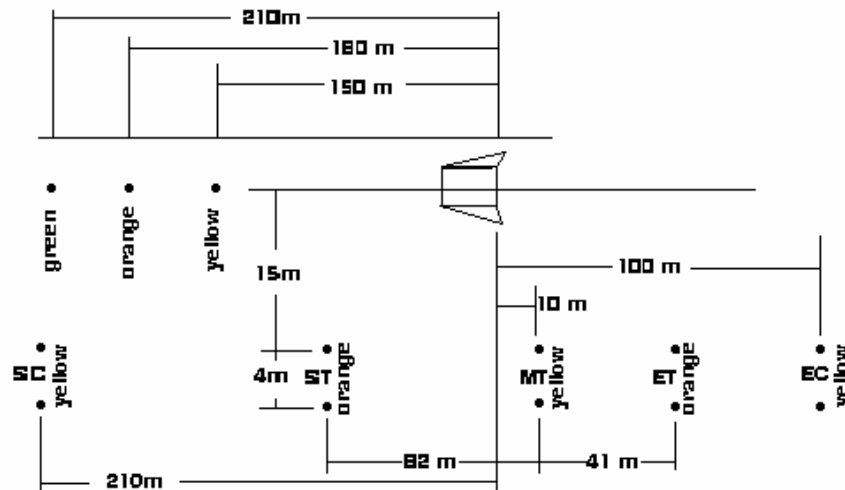

Jump Course Dimensions and Tolerances		
Dimensions	Tolerances	Range
210m (688' 11 <sup>3</sup> / <sub>4</sub> "	1.0%	207.9m - 212.1m (682' 1" - 695' 10 5/8")
180m (590' 6 <sup>1</sup> / <sub>2</sub> "	1.0%	178.2 - 181.8m (584' 7 <sup>3</sup> / <sub>4</sub> " - 596' 5 <sup>1</sup> / <sub>2</sub> "
150m (492' 1 <sup>1</sup> / <sub>2</sub> "	1.0%	148.5 - 151.5m (487' 2 <sup>1</sup> / <sub>2</sub> " - 497' 1 <sup>1</sup> / <sub>2</sub> "
100m (328' 1"		90.0 - 102.0m (301' 8 <sup>1</sup> / <sub>4</sub> " - 334' 7 <sup>3</sup> / <sub>4</sub> "
82m (269' 1 <sup>1</sup> / <sub>4</sub> "	0.5%	81.59 - 82.41m (267' 8 <sup>1</sup> / <sub>4</sub> " - 270' 4 <sup>1</sup> / <sub>2</sub> "
41m (134' 6 <sup>1</sup> / <sub>4</sub> "	0.5%	40.795 - 41.205m (133' 10" - 135' 2 <sup>1</sup> / <sub>4</sub> "
4m (13' 1 <sup>1</sup> / <sub>2</sub> "	2.5%	3.9 - 4.1m (12' 9 <sup>1</sup> / <sub>2</sub> " - 13' 5 <sup>1</sup> / <sub>2</sub> "
15m (49' 2 <sup>1</sup> / <sub>2</sub> "		
to ramp high center	1.0%	14.85 - 15.15m (48' 8 <sup>3</sup> / <sub>4</sub> " - 49' 8 <sup>1</sup> / <sub>2</sub> "
- to 150m, 180m	± .5m	14.50 - 15.50m (47' 6 <sup>3</sup> / <sub>4</sub> " - 50' 10 <sup>1</sup> / <sub>4</sub> "
10m (32' 9 <sup>3</sup> / <sub>4</sub> "	2%	9.8 - 10.2m (32' 1 <sup>3</sup> / <sub>4</sub> " - 33' 5 <sup>1</sup> / <sub>2</sub> "

The ramp must be parallel to the jump course and slightly open. The tolerance for standard jumping is between **+1.00** degrees and **+2.50** degrees open, **with +2.00 recommended**. Open means that the high end of the ramp is turned away from the jump course while the center of the high end remains on the 15m dimension.

The 15 MT buoy may be sunk below 1/2 of its volume. However, it must be clearly visible.



# American Water Ski Association

## TECHNICAL CONTROLLERS' HANDBOOK

Revised 2007

Contributions By: Merle Vasbinder, Tom Dusin, Gene Davis, Dave Clark, Ed Brazil and others.

### Ramp Setting Chart

Scale: one small division = 1/4 inch

Metric measurements in ( )

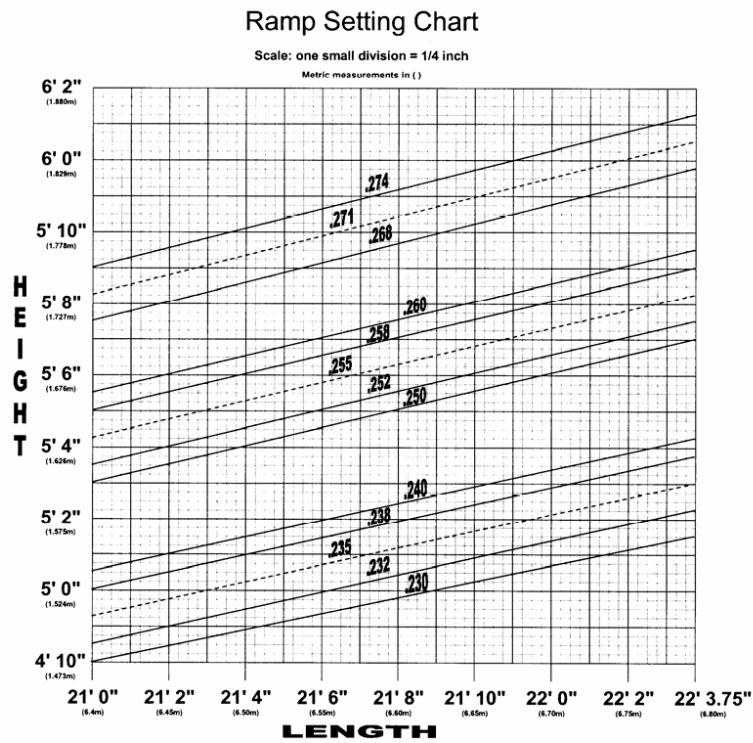

### Length

**Instructions:** For any particular ramp setting, a combination of HEIGHT at top edge and LENGTH out of water enclosed within the solid line is allowable. A combination that lies on the dotted line is the most desirable. Record Capability standards of  $\pm .003$  in ratio are indicated by narrower areas above. Note: Some Open Women may qualify to jump on a .255 ramp, see Rule 9.16c(4).



# American Water Ski Association

## TECHNICAL CONTROLLERS' HANDBOOK

Revised 2007

Contributions By: Merle Vasbinder, Tom Dusin, Gene Davis, Dave Clark, Ed Brazil and others.

### Official Trick Course

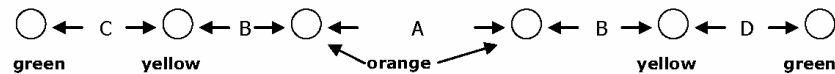

	<b>Dimension</b>	<b>Tolerance</b>	<b>Lower</b>	<b>Upper</b>
A	175 m (574' 2")	±10%	157.5 m (516' 9")	192.5 m (631' 6")
B	15 m (49' 2½")	±10%	13.5 m (44' 3½")	16.5 m (54' 1½")
C	50 m (164' ½")	± 10%	45 m (147' 7½")	55 m (180' 5½")

An Optional green buoy marked by dimension "C" 50 meters prior to the Yellow buoys

### Trick Speed Calibration Times

Times for speedometer calibration at trick speeds are for the speed indicated from the slalom course entry gates to the third buoy (109 m).

<b>Mph</b>	<b>Kph</b>	<b>Ideal</b>	<b>Tolerance</b>
11	17.7	22.17	21.20-23.33
12	19.3	20.32	19.51-21.20
13	20.9	18.76	18.06-19.51
14	22.5	17.42	16.82-18.06
15	24.1	16.25	15.73-16.82
16	25.8	15.24	14.78-15.73
17	27.4	14.34	13.93-14.78
18	29.0	13.55	13.18-13.93
19	30.6	12.83	12.50-13.18
20	32.2	12.19	11.89-12.50
21	33.8	11.61	11.34-11.89



# American Water Ski Association

## TECHNICAL CONTROLLERS' HANDBOOK

Revised 2007

Contributions By: Merle Vasbinder, Tom Dusin, Gene Davis, Dave Clark, Ed Brazil and others.

### Tournament Classification Requirements

Tournament Classification	Regular Local Class C	National Entry Class E	Ranking List Class L	World Record Class R
<b>Applicability</b>				
EPs for Nationals	2	1	1	1
AWSA National Records	No	Yes	Yes	Yes
IWSF Ranking List	No	No	Yes	Yes
World Records	No	No	No	Yes
<b>General Requirements</b>				
<b>Chief Officials</b>				
Judge	Reg. or Sr.	Sr.	Sr. (W)	Sr. (W)
Scorer	Reg. or Sr.	Sr.	Sr. (A)	Sr. (A)
Driver	Reg. or Sr.	Sr.	Sr. (A)	Sr. (A)
Safety Director	State	State	State	State
Technical Controller	No	Yes	Yes (W)	Yes (W)
Appointed Judges	3	5	5 (A) 1 Pan-Am (P)	5 (A) 1 Pan-Am (P)
Conflict of Interest Rule	No	Yes	Yes (A)	Yes (A)
Site Certification	Measured	Survey	Survey (W)	Survey (W)
Judges Towers	3m high, both sides recom.	3m/44° both sides	3m/44° both sides	3m/44° both sides
Trick Timing Devices	Manual	Automatic	Automatic (W)	Automatic (W)
Speed Control	Yes	Yes	Yes	Yes
<b>Slalom Requirements</b>				
End Course Video	No	Yes	Yes (A)	Yes (A)
Minimum Avg. Buoy Width	None	11.48m	11.48m (W)	11.48m (W)
Event Judges	5 (or 3) Ast. or up	5 Total, min 1 R/S each tower and Towboat	5 total, min. 3 Sr. (W)	5 Sr. (W)
Optional Video EJ's	Same	3 Reg. or Sr.	2 Sr. & 1 Reg. (W)	3 Sr. (W)
<b>Tricks Requirements</b>				
Video	Recommended	Required	Required (W)	Required (W)
Event Judges	5 (or 3) Ast. or up	5 Reg. or Sr.	5 total, at least 3 Sr. (W)	5 Sr. (W)
EJ's w/ immediate Video	Same	3 Reg. or Sr.	3 Sr. (W)	3 Sr. (W)
Boat Judge	Ast.	Ast. or up or Reg or Sr Driver	Reg. (A)	Reg. (W)
Shore Timer	Ast. Recom.	Reg. or Sr.	Reg. or Sr. (W)	Reg. or Sr. (W)
Backup Timer	Ast. Recom.	Ast. or up	Reg. or Sr. (W)	Reg. or Sr. (W)
<b>Jumping Requirements</b>				
Video	No	No	No	Required(W)
Distance Calc. Method	M/B or Comp.	Computer	Computer (W)	Computer (W)
Event Judges	3 Ast. or up	3 Reg. or Sr.; 1 Shore may be ast.	3 total, at least 2 Sr. (W)	3 Sr. (W)
Meter Readers	2 (or 1) Ast. or up recommended	2 each, with 1 Reg. or Sr.	2 each, with 1 Reg. or Sr. (A)	2 each, with 1 Reg. or Sr. (W)
Notes: (W) as required by IWSF World Rules. (P) as required by IWSF Pan-American Region Rules. (A) as required by AWSA Rules, which are more requiring than the associated Pan-American or World rules (if any).				



# American Water Ski Association

## TECHNICAL CONTROLLERS' HANDBOOK

Revised 2007

Contributions By: Merle Vasbinder, Tom Dusin, Gene Davis, Dave Clark, Ed Brazil and others.

### Slalom Timing Chart Standard Tolerance ABT Chart

*(Required in Class C, E, L or R Events)*

BOAT SPEED		Score:	0-0.5	1-1.5	2-2.5	3-3.5	4-4.5	5-5.5	All 6
KPH	MPH	Display	0	1	2	3	4	5	6
58	36.0	Fast	1.64	4.15	6.67	9.20	11.73	14.25	15.92
		<b>Ideal</b>	<b>1.68</b>	<b>4.22</b>	<b>6.77</b>	<b>9.31</b>	<b>11.86</b>	<b>14.40</b>	<b>16.08</b>
		Slow	1.71	4.28	6.84	9.41	11.97	14.53	16.22
55	34.2	Fast	1.73	4.37	7.03	9.69	12.35	15.02	16.78
		<b>Ideal</b>	<b>1.77</b>	<b>4.45</b>	<b>7.13</b>	<b>9.82</b>	<b>12.50</b>	<b>15.19</b>	<b>16.95</b>
		Slow	1.80	4.51	7.23	9.93	12.64	15.34	17.12
52	32.3	Fast	1.83	4.62	7.43	10.24	13.05	15.87	17.72
		<b>Ideal</b>	<b>1.87</b>	<b>4.71</b>	<b>7.55</b>	<b>10.38</b>	<b>13.22</b>	<b>16.06</b>	<b>17.93</b>
		Slow	1.91	4.78	7.65	10.52	13.39	16.25	18.13
49	30.4	Fast	1.94	4.90	7.87	10.85	13.83	16.81	18.78
		<b>Ideal</b>	<b>1.98</b>	<b>5.00</b>	<b>8.01</b>	<b>11.02</b>	<b>14.03</b>	<b>17.04</b>	<b>19.03</b>
		Slow	2.03	5.08	8.13	11.18	14.22	17.27	19.27
46	28.6	Fast	2.06	5.21	8.37	11.54	14.71	17.88	19.98
		<b>Ideal</b>	<b>2.11</b>	<b>5.32</b>	<b>8.53</b>	<b>11.74</b>	<b>14.95</b>	<b>18.16</b>	<b>20.27</b>
		Slow	2.16	5.42	8.68	11.93	15.18	18.42	20.56
43	26.7	Fast	2.20	5.56	8.94	12.33	15.71	19.10	21.34
		<b>Ideal</b>	<b>2.26</b>	<b>5.69</b>	<b>9.13</b>	<b>12.56</b>	<b>15.99</b>	<b>19.42</b>	<b>21.68</b>
		Slow	2.32	5.81	9.30	12.78	16.27	19.75	22.03
40	24.9	Fast	2.36	5.97	9.60	13.23	16.86	20.50	22.89
		<b>Ideal</b>	<b>2.43</b>	<b>6.12</b>	<b>9.81</b>	<b>13.50</b>	<b>17.19</b>	<b>20.88</b>	<b>23.31</b>
		Slow	2.50	6.26	10.02	13.78	17.53	21.27	23.74
37	23.0	Fast	2.54	6.44	10.35	14.27	18.19	22.11	24.70
		<b>Ideal</b>	<b>2.63</b>	<b>6.62</b>	<b>10.61</b>	<b>14.59</b>	<b>18.58</b>	<b>22.57</b>	<b>25.20</b>
		Slow	2.71	6.79	10.86	14.93	18.99	23.06	25.73
34	21.1	Fast	2.76	6.99	11.24	15.49	19.74	23.99	26.81
		<b>Ideal</b>	<b>2.86</b>	<b>7.20</b>	<b>11.54</b>	<b>15.88</b>	<b>20.22</b>	<b>24.56</b>	<b>27.42</b>
		Slow	2.95	7.41	11.85	16.29	20.73	25.16	28.08
31	19.3	Fast	3.02	7.65	12.29	16.93	21.58	26.24	29.31
		<b>Ideal</b>	<b>3.14</b>	<b>7.90</b>	<b>12.66</b>	<b>17.42</b>	<b>22.18</b>	<b>26.94</b>	<b>30.08</b>
		Slow	3.25	8.15	13.05	17.93	22.82	27.70	30.90
28	17.4	Fast	3.33	8.43	13.55	18.68	23.81	28.94	32.33
		<b>Ideal</b>	<b>3.47</b>	<b>8.74</b>	<b>14.01</b>	<b>19.29</b>	<b>24.56</b>	<b>29.83</b>	<b>33.30</b>
		Slow	3.61	9.07	14.51	19.94	25.37	30.80	34.37
25	15.5	Fast	3.71	9.40	15.11	20.83	26.54	32.26	36.04
		<b>Ideal</b>	<b>3.89</b>	<b>9.79</b>	<b>15.70</b>	<b>21.60</b>	<b>27.50</b>	<b>33.41</b>	<b>37.30</b>
		Slow	4.07	10.21	16.34	22.46	28.58	34.68	38.70





# American Water Ski Association

## TECHNICAL CONTROLLERS' HANDBOOK

Revised 2007

Contributions By: Merle Vasbinder, Tom Dusin, Gene Davis, Dave Clark, Ed Brazil and others.

### Jumping Event Timing Tolerance Table

<b>RECORD</b>	<b>Boat Speed</b>		<b>1st Segment Times</b>				<b>2nd Segment Times**</b>			
<b>Tolerances</b>	Kph	Mph	Balk	Fast	Ideal	Slow	Fast	Ideal	Slow	RTB*
Apply only when the skier is at the maximum speed for his/her age division, otherwise use the table below.	<b>57</b>	35.4	5.06	5.11	<b>5.18</b>	5.25	2.36	<b>2.40</b>	2.466	2.71
	<b>54</b>	33.6	5.34	5.39	<b>5.47</b>	5.55	2.54	<b>2.59</b>	2.66	2.86
	<b>51</b>	31.7	5.65	5.70	<b>5.79</b>	5.88	2.68	<b>2.73</b>	2.81	3.01
	<b>48</b>	29.8	6.00	6.05	<b>6.15</b>	6.25	2.84	<b>2.89</b>	2.98	3.18
	<b>45</b>	28.0	6.40	6.45	<b>6.56</b>	6.68	3.01	<b>3.08</b>	3.17	3.37
	Tolerance basis:		+/- 0.8 kph (0.50 mph)				+1/-1.5 kph (+0.62/-0.93 mph)			
<b>STANDARD</b>	<b>Boat Speed</b>		<b>1st Segment Times</b>				<b>2nd Segment Times**</b>			
<b>Tolerances</b>	Kph	Mph	Balk	Fast	Ideal	Slow	Fast	Ideal	Slow	RTB*
Apply these tolerance values at most Class C tournaments, and in Record tournaments where the skier is at speeds lower than the maximum for his/her age division.	<b>57</b>	35.4	5.02	5.07	<b>5.18</b>	5.29	2.36	<b>2.40</b>	2.48	2.73
	<b>54</b>	33.6	5.30	5.35	<b>5.47</b>	5.59	2.54	<b>2.59</b>	2.68	2.88
	<b>51</b>	31.7	5.60	5.65	<b>5.79</b>	5.93	2.68	<b>2.73</b>	2.84	3.04
	<b>48</b>	29.8	5.95	6.00	<b>6.15</b>	6.31	2.84	<b>2.89</b>	3.01	3.21
	<b>45</b>	28.0	6.34	6.39	<b>6.56</b>	6.74	3.01	<b>3.08</b>	3.21	3.41
	<b>42</b>	26.1	6.78	6.83	<b>7.03</b>	7.24	3.21	<b>3.28</b>	3.43	3.63
	<b>39</b>	24.2	7.29	7.34	<b>7.57</b>	7.81	3.43	<b>3.51</b>	3.69	3.89
	Tolerance basis:		+/- 1.21 kph (0.75 mph)				+1/-2.0 kph (+0.62/-1.24 mph)			
<b>"WIDER"</b>	<b>Boat Speed</b>		<b>1st Segment Times</b>				<b>2nd Segment Times**</b>			
<b>Tolerances</b>	Kph	Mph	Balk	Fast	Ideal	Slow	Fast	Ideal	Slow	RTB*
In events run as Class C or below, these wider tolerance values may be used on an exception basis only, and ratings above Expert are not permitted under these circumstances. See Rule 9.17.	<b>57</b>	35.4	4.97	5.02	<b>5.18</b>	5.34	2.36	<b>2.40</b>	2.50	2.75
	<b>54</b>	33.6	5.24	5.29	<b>5.47</b>	5.65	2.54	<b>2.59</b>	2.71	2.91
	<b>51</b>	31.7	5.54	5.59	<b>5.79</b>	6.00	2.61	<b>2.73</b>	2.87	3.07
	<b>48</b>	29.8	5.88	5.93	<b>6.15</b>	6.39	2.84	<b>2.89</b>	3.04	3.24
	<b>45</b>	28.0	6.26	6.31	<b>6.56</b>	6.83	2.92	<b>3.08</b>	3.24	3.44
	<b>42</b>	26.1	6.69	6.74	<b>7.03</b>	7.34	3.21	<b>3.28</b>	3.47	3.67
	<b>39</b>	24.2	7.19	7.24	<b>7.57</b>	7.93	3.32	<b>3.51</b>	3.74	3.94
	Tolerance basis:		+/-1.77 kph (1.10 mph)				+1/-2.5 kph (+.062/-1.56 mph)			

**\*\*Note:** The above 2nd Segment boat speed tolerances presume that the boat speed will rise to 3 kph faster than the baseline speed once the skier is in the air (except 4.5 kph faster at 57 kph/"35" mph).

\*Alternatively, use the "RTB" slow time limit if the skier chooses the "return to baseline speed" basis, or is not sufficiently aggressive to engage the jump switch at the base of the ramp. If a skier who selects the faster second segment does not properly engage the switch at the ramp, then the tolerance as indicated in the RTB column applies.

If the skier balks, examine only the 1<sup>st</sup> segment time against this table. See Rule 9.09(a).



# American Water Ski Association

## TECHNICAL CONTROLLERS' HANDBOOK

Revised 2007

Contributions By: Merle Vasbinder, Tom Dusin, Gene Davis, Dave Clark, Ed Brazil and others.

### PPM CORRECTION VARIABLES

by Doug Crook, President - Ingenuity Inc.

Calculating and applying the proper atmospheric correction, parts per million (PPM), to an EDM distance measurement is EXTREMELY important. The density of the atmosphere varies with changes in atmospheric pressure and temperature. The speed of the EDM light beam used to measure a distance varies with atmospheric density. Use as accurate an atmospheric pressure and temperature as you can obtain to calculate the PPM correction the most accurate atmospheric pressure is obtained by using an altimeter / barometer. The average atmospheric pressure at sea level is approximately 29.92 inches of mercury. As elevation increases, the pressure decreases. Remember that the atmospheric or barometric pressure that the Weather Bureau gives is corrected to sea level. DO NOT use this value directly for PPM calculations unless you are at sea level. The decrease is about one inch of mercury per thousand foot increase in elevation. At an elevation of 5000 feet the actual (uncorrected) atmospheric pressure will be about 24.92 inches of mercury. The UNCORRECTED value MUST be used in the PPM calculations. The most accurate temperature can be obtained using a thermometer. The temperature must be taken in the shade in still air to give the most accurate reading.

The temperature and atmospheric pressure is used in combination to give a correction factor stated in parts per million. The correction is applied to the slope distance. Virtually all modern EDM units have a way of entering the PPM correction, either as a PPM value or the raw temperature and pressure.

An improper or invalid PPM value can cause inaccuracy in a distance measurement. Incorrect values of temperature and/or atmospheric pressure or a combination of the two can result in an invalid PPM correction. Most EDM can accept temperature in Fahrenheit or Celsius units and pressure in inches of mercury, millimeters of mercury, or millibars. Make sure you are entering the proper units.

Some Values:

1 Part per Million = .001 ft. per 1000 ft.

10 PPM = .01 ft. per 1000 ft.

2 degrees Fahrenheit = 1 PPM

.1 inch of mercury = 1 PPM

The best way to test the effect of the PPM correction is to measure a 1000 foot distance using 0 (zero) PPM and then shoot the same distance using 100 PPM. You should see a difference in the distance of about .1 foot.



# American Water Ski Association

## TECHNICAL CONTROLLERS' HANDBOOK

Revised 2007

Contributions By: Merle Vasbinder, Tom Dusin, Gene Davis, Dave Clark, Ed Brazil and others.

### Prism Offsets

by Chris Cothrun

In this installment of The Technical Side we are going to talk about prism offsets and what can happen when you ignore the differences in offsets that exist. To start off, I will give some background information on prisms that are used with electronic distance meters (EDM). These prisms are called corner cube prisms or retroreflectors. This is to differentiate them from the ones that Newton used to make rainbows or the one in your survey instrument that makes the image appear right side up. They are called corner cubes because the three surfaces that make up the 'pyramid' are at 90 degree angles to each other and thus form the corner of a cube. As you have noticed, light entering the prism is reflected back to its source, even at relatively large angles of incidence. The angle of incidence is the angular difference between the incoming light rays and an imaginary line perpendicular to the face of the prism. A beam of light entering the prism bounces off all three back surfaces and exits at the same angle it entered. Light also slows down when it enters glass. Both of these factors make the distance measured longer than the distance to the front face or even the back of the corner cube. This distance is called the offset. This offset is a constant amount that the distance measured is corrected for a particular prism. Further complicating things is the fact that various manufacturers position the corner cube differently in the prism housing and the speed of light changes in different kinds of glass. This results in a multitude of prism offsets. Below are some manufacturers' offsets.

Hewlett-Packard		-28mm
AGA		0mm
Sokkia / Lietz	0mm, -30mm,	-40mm
Retro Ray (Lewis & Lewis / Lietz)	-30mm,	-40mm
K & E	-30mm,	-40mm
Precision International		-40mm
Kern		-70mm
TOPCON	0mm,	-30mm
Zeiss	-23.4mm,	-40mm
Omni Optical	0mm, -30mm, -34mm,	-40mm
Wild		-34mm

As you can see, offsets vary greatly. There are different reasons for this. Some manufacturers designed prism offsets in to correct for the difference between the actual



# American Water Ski Association

## TECHNICAL CONTROLLERS' HANDBOOK

Revised 2007

Contributions By: Merle Vasbinder, Tom Dusin, Gene Davis, Dave Clark, Ed Brazil and others.

plumb line through an EDM and the position of the photo diode in the EDM. Others sought to minimize the effects of having large angles of incidence (not pointing the prism at the gun) on the measured distance. If you are lucky, all your prisms were made by the same manufacturer and have the same offset. Unfortunately, old prisms from that retired EDM are often still around and get pressed into service. What happens to your survey when different offset glass is mixed? We will take the most common offsets, 0mm and -30mm, and throw some numbers around. The difference between the two, 30mm, is about a tenth of a foot. On a relatively short shot, say 300ft., this gives an accuracy of about 1 in 3000, not very good. As your distance increases the ratio will increase but never get as good as it could be. Another way to look at that 30 mm or tenth difference is 100ppm in a 1000ft shot. That extra care taken in measuring the temperature and pressure would have been wasted. What if your field procedures allowed that tenth to accumulate? It wouldn't take many shots to build up an error that would be unacceptable even for rough construction staking. In so many words, don't mix glass!

So you aren't going to use all those different prisms with each other. What if you want to check some questionable prisms that aren't marked with an offset? Do they have the same offset as the rest of your glass? Measure the length from the face of the prism to the tip (how tall the 'pyramid' is.) and call it A. Then measure the distance from the face of the prism to the center of the 5/8x11 thread (it might be easiest to measure from the front of the prism can and subtract the difference from the front of the can to the prism face out.) and call this B. The prism offset will be  $(A \times 1.509) - B$ . The 1.509 is the refractive index (or change in the speed of light) of the most common glass used for prisms. For some prisms this might be different, ranging from 1.50 to 1.57. Prisms from different manufacturing runs can vary about 1mm. As a check, compare EDM measurements to a prism with a known offset with measurements to the unknown prism.



# American Water Ski Association

## TECHNICAL CONTROLLERS' HANDBOOK

Revised 2007

Contributions By: Merle Vasbinder, Tom Dusin, Gene Davis, Dave Clark, Ed Brazil and others.

## Procedure for setting up a tripod & Leveling Total Station

This can be one of the most time consuming procedures in surveying, and one of the most critical. Any error in setting up the tripod is carried through the entire survey. Generally small setup errors (1 or 2 mm) are not a problem because they are non-systematic, and the EDM on the Total Stations have an error of  $\pm 3-5$  mm. I suggest the following procedure.

1. **Setup tripod.** Open up the tripod and extend the legs. Adjust the approximate height so that the total station will be at eye level. Set one leg on the ground (stomp it in). *This will be the "anchor" leg, and should not be adjusted in the following procedure.* Attach the total station at this point; Holding the other two tripod legs, and keeping the anchor leg in the same position. Place your toe near the point on the ground (your foot will assist you in locating the point on the ground through the plummet), pick up the two legs and move the tripod while looking through the optical plummet, until it is over the point. Do not worry about having the tripod level. When you are over the point, anchor the two remaining legs. Check the plummet; you should still be over your point.
2. **Level the Tripod.** By changing the length of the two legs you used to position the tripod, level the top surface of the tripod using the bulls-eye level. The bubble should be within the inner circle. Be as precise as possible. *Do not change the length of the anchor leg.* After this procedure you should still be directly over the same point you were over in step 1.
3. **Leveling the Instrument.** Align the long bubble-level between two posts of the tribrac. *Turning BOTH posts in opposite directions, center the bubble in the level.* Turn the instrument 90° to align it with the third leg. *Turn only the third post until level.* The instrument is now level. Repeat this step to fine tune the level.
4. **Check alignment over point.** Use the optical plummet on the instrument to check that you are still over your point. If you are not you may slide the entire tribrac assembly slightly to get over the point. If you move the tribrac, repeat the instrument leveling step 3.



# American Water Ski Association

## TECHNICAL CONTROLLERS' HANDBOOK

Revised 2007

Contributions By: Merle Vasbinder, Tom Dusin, Gene Davis, Dave Clark, Ed Brazil and others.

### Course Surveys

In order to ensure that the courses conform to record capable standards a survey of the courses must be completed. This will provide a check of all relative dimensions on the water.

#### 15.03 Certification of Competition Courses

- (a) The Technical Committee shall devise and publish standards for the certification of competition courses. Such standards shall require that all slalom and jump course buoys and the jump ramp and meter station pivot centers be located by appropriate survey methods. The inter-relationships among these objects shall be derived therefrom, and must be within the location tolerances shown in the Official Slalom and Jump Course Diagrams in the Appendix.
- (b) The competition slalom and jump courses required for the events scheduled for the tournament must be certified in advance of the tournament by either one of the following two procedures:
  - (1) The slalom course and the jump course shall be surveyed by either a licensed surveyor, acting as such, or by a person independent of the tournament sponsors who satisfies the Chairman of the Technical Committee as to his competence prior to the survey, no more than 90 but no less than 30 days prior to the tournament. The survey and supporting detail shall be forwarded to the Appointed Technical Controller for the tournament at least one week prior to the tournament.
  - (2) Alternatively, the Appointed Technical Controller may certify the courses by his own survey prior to the tournament, and shall attach that survey and its computer analysis showing the actual buoy locations to the Technical Controller's Report from the tournament, along with any adjustments which were made.

The following instructions are taken from the approved AWSA survey reduction spreadsheets provided by Dave Clark.



# American Water Ski Association

## TECHNICAL CONTROLLERS' HANDBOOK

Revised 2007

Contributions By: Merle Vasbinder, Tom Dusin, Gene Davis, Dave Clark, Ed Brazil and others.

AMERICAN WATER SKI ASSOCIATION SITE SURVEY AIDS Ver 3.44, APR 2004

---

The complete Water Ski Site Survey Aids package consists of this instruction file, plus a set of worksheet template files. Some of these are designed for laying out and installing a Slalom and/or Jump Course, and others for reducing the data obtained from surveying an existing Slalom Course or Jumping Site (including the judge's towers and/or the jump distance measurement system) in preparation for a Water Ski competition which is being sanctioned by the AWSA. The underlying layouts and standards are also compatible with IWSF Rules.

There is a separate section in these instructions for Slalom and Jump site certification, each of which addresses a number of topics:

1. Orientation and designation standards that are assumed. Field data recording forms are included—make several copies, and utilize one each time a survey is conducted.
2. Brief notes on conducting the survey itself, following one of the various surveying procedures which have been developed for this purpose. Refer to the AWSA Technical Handbook for a more complete discussion on each of these surveying procedures and its applicability to specific site situations.
3. Instructions for utilizing the worksheet templates to reduce the survey data, and guidelines on interpreting the results.

The survey aid templates which are included may be processed on any personal computer which has spreadsheet software installed. These use basic functions only, and may be utilized with any version of Lotus 1-2-3 from release 1A on, Excel or with any other spreadsheet utility which is capable of loading (or converting from) a .WKS format file.

**INSTALLATION / SYSTEM PREPARATION:** First, place the WSSURV34.EXE compressed distribution file into a suitable directory on your hard drive, then execute it to extract all of the included worksheets and instruction files. The instruction files may then be viewed onscreen with the BROWSE command, or may be printed (eighteen pages in total), by entering the following command from the DOS command prompt: COPY READSRV.TXT PRN (issued from the applicable directory) Requests for assistance, comments or suggestions for changes to these worksheet templates or the accompanying instructions and guidelines should be addressed to:

The Chairman of the AWSA Technical Committee  
Care of: The American Water Ski Association  
1251 Hold Cow Road—Polk City, FL 33868

The balance of these instructions includes one section on setting out and installing courses using the one-point (EDM) or two-point survey methods, followed by additional sections on certifying an existing Slalom Course and/or Jump Site using any of three survey methods.



# American Water Ski Association

## TECHNICAL CONTROLLERS' HANDBOOK

Revised 2007

Contributions By: Merle Vasbinder, Tom Dusin, Gene Davis, Dave Clark, Ed Brazil and others.

### JUMP AND SLALOM SITE INSTALLATION INSTRUCTIONS

Explanation: Working from one or two survey base point(s) located on the shore alongside the area where courses are to be laid out, and given sightings to two reference buoys (or markers) along which the course is to be aligned, these worksheets will generate the sighting angles (and EDM distance values for the one-point method) for locating all of the standard course buoys and judge's tower locating marks, and for a jump site, also the sightings to the ramp center and anchor locations, plus recommended meter layout and/or video measurement setup.

Separate installation templates are provided for the single-point (EDM) angle-and-distance method, or the two-point angle-angle method using two surveying instruments.

For each of these methods, there are two installation templates provided, the first for installing a Slalom Course alone, and the other for a Jumping and/or Combined Site. The Combined Site includes a Slalom Course laid out parallel to the Jump Course, with the recommended arrangement (shown below) placing the Slalom Course boat path outside the 19 meter line of the Jump Course (with three boat gate buoys being shared—those marked as #). But ANY desired parallel interrelationship may be created, by using the provided shift adjustment parameters in cells B138 and C138.

### INTERRELATED SLALOM AND JUMP COURSE LAYOUT

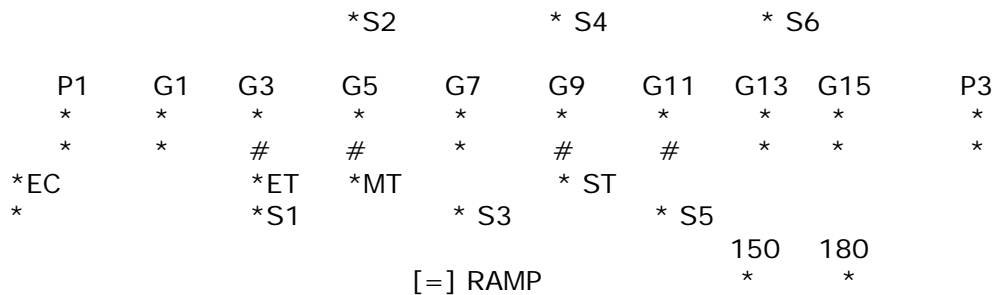

### COURSE LAYOUT PREPARATIONS GENERAL

First, position a reference buoy or marker at a point located near each end of the course which is to be laid out. For a jump course, these will mark the 15m line of the boat gates—one should be placed at the approximate location of the 15EC end-course buoy, and the other on the extension of the 15m line at the approximate level of the 180 meter buoy which defines the beginning of the course. For a Slalom course, these will mark the course centerline, and should be placed about at the desired locations of the center of the entrance gates at either end of the course. While the up-and-down-course locations of these two reference markers are not critical (and may be adjusted for later, see below), their side-to-side positioning IS important, since they define the boat path as specified above.





# American Water Ski Association

## TECHNICAL CONTROLLERS' HANDBOOK

Revised 2007

Contributions By: Merle Vasbinder, Tom Dusin, Gene Davis, Dave Clark, Ed Brazil and others.

In the special case where you already have one course in place, and intend to install the other course in an integrated manner, we have provided some specific guidance on the 4<sup>th</sup> page of this section of the instructions. See "Adding an Integrated Course" below.

Next, choose your survey point(s) and set up your instrument(s). For the single-point method, choose a convenient location on shore near the center of where the course is to be laid out, and identify a sighting reference point to establish your baseline (zero angles to your left, 180 degrees to your right). Then shoot angle and EDM distance to each of the two reference markers. If your instrument automatically provides corrected horizontal distances, then that's all you need to prepare. Otherwise, record the Vertical distance from the EDM unit to the reflector when taking these two preliminary sightings (if your instrument will give you that), or else record the vertical angle as well on each of the two reference mark sightings.

For the two-point method, set up your two survey instruments at points on shore which are about 200-250 meters apart—or roughly near the end points of the course(s) to be laid out. Align both instruments to this common baseline (as you face the course, angle zero and Station "A" are to your left, 180 degrees and Station C to the right). Carefully measure and record the distance between the instruments (with an EDM if you have it, or else with a calibrated tape), then sight the two reference markers from each instrument, and record these sightings.

### **GENERATING THE COURSE LAYOUT SIGHTINGS**

Take the data from these two preliminary sightings to any IBM PC (or compatible) which has any version of Lotus 1-2-3 (or any other spread-sheet processor which is capable of loading a .WKS type file). If you have a laptop or "notebook" variety available, bring it with you to the site and produce the installation data on the spot. Start up your spreadsheet program and load either the SLMINSTn or JMPINSTn template (use n=1 for the single-point (EDM) version, or n=2 for the two-point version) from your working copy of the distribution diskette, or from your hard drive if you've installed them this way. Use SLMINSTn if you are installing a Slalom Course alone or JMPINSTn where you are laying out a Jumping or Combined Site.

Enter the name of the site and the survey date in the heading section at the top of the worksheet, plus notes on the instrument base points and reference line. For the two-point versions, also enter the A-C baseline distance (in meters) in Cell D11. For a Jumping or Combined Site, you also need to indicate whether your sightings are being taken from the Ramp shore or the Boat Gate shore of the lake—enter either a 1 or a -1 in Cell J11 to indicate which orientation applies.

For a Slalom course, the worksheet will also help you position markers for the two required judge's towers. At each end of the course, there will be two marker sightings generated, both of which will be placed.



# American Water Ski Association

## TECHNICAL CONTROLLERS' HANDBOOK

Revised 2007

Contributions By: Merle Vasbinder, Tom Dusin, Gene Davis, Dave Clark, Ed Brazil and others.

exactly on the recommended 44 degree line from the respective entrance gate center, and at distances back from the course centerline of 35 and 50 meters (about 115 and 165 feet). These two off-center default values may be changed if necessary. For the Slalom-only worksheet, replace the contents in cells C56+. For the Combined worksheet, you will need to edit the formulas which appear in cells C178+, changing the constant values from 35 and 50 to whatever off-center distances are more appropriate to your shore contours.

For a Jump site, the worksheet will help you position a number of other objects, in addition to the boat course and skier buoys. These include recommended Jump Meter locations, assuming the shoreline is roughly parallel to the course. Meters A and C are planned about 3 M back from the shoreline, and are based on an estimated ramp-to-shore distance in Cell G11 -- the default value of 40 M (about 130 ft) should be revised as necessary. Video camera markers plus reference grid buoy positions may also be generated. Input the details of your planned layout into the section below cell O45. In this particular area, the X and Y coordinates you provide are assumed to be relative to the jump Ramp as (0,0), so X coordinates will be down course from the ramp, and Y coordinates will be relative to the ramp centerline, with positive numbers to the right (toward the boat course) and negative numbers to the left. Finally, the recommended ramp anchor points are appropriate for water depths to about 10 ft—these sightings are not adjustable, but you will probably want to position the anchors further out in greater water depths.

The Jump site installation template now also includes the additional objects needed for a Ski Flying course. This includes an additional 240m skier turn buoy, and an additional row of boat gates at 21.3m from the ramp—these will coincide with slalom boat gates where you have the typically integrated layout.

If you are using the single-point method and your EDM unit does NOT automatically calculate corrected horizontal distances for you, then the worksheet will be working with slope distances throughout, and so you will need to enter the vertical height differential in Cell E11 (if your EDM unit calculates it for you), or else you can supply the vertical angle for the two reference sightings in cells O16+, and the worksheet will then compute the necessary height value for you.

Then enter the sighting data from each of the two reference marks. Examine the Course Coordinates of these two reference marks (shown near the top of the worksheet), and determine if the up-and-down- course positioning is appropriate. If not, you may enter a shift amount in Cell B11, to relocate the course either right or left as necessary. If you are working with the Jumping Site worksheet and plan to install a parallel Slalom Course, shift offset values may be entered in Cells B138 and C138 to adjust the location of the Slalom Course, relative to the Jump Course. Should you find it necessary to make any adjustments in the interrelationship, remember that the two reference markers are used to determine the 15m line of the boat gates for the Jump Course first—then the Slalom Course may be adjusted relative to that resulting Jump Course location.



# American Water Ski Association

## TECHNICAL CONTROLLERS' HANDBOOK

Revised 2007

Contributions By: Merle Vasbinder, Tom Dusin, Gene Davis, Dave Clark, Ed Brazil and others.

The interior boat gate width for the Slalom Course may be modified— the standard value of 1.15 meters is recommended where spherical boat guide buoys are being used on these interior gates, and a narrower width of 1.10 meters is recommended where narrower non-spherical types (like “bullet” buoys) are to be used. This adjustable parameter appears near the top of the Slalom section of either template file. Once you’ve got the recommended sightings for all the objects you need to place, check the sightings for the Slalom Tower markers and/or the jump Meter station markers to be sure they fall in the appropriate areas on shore. You may need to adjust the off-center distance values for these objects, to accomplish that.

After making any such necessary adjustments, the worksheet presents the sightings (angles and/or EDM distances) from your base point(s) to all of the standard buoys, slalom judge’s towers, ramp center and recommended ramp anchors, plus jump meters or Video Jump reference grids plus cameras. Print the worksheet out (the range and setup parameters are pre-defined to give you all the section necessary), and take that printout sheet with you to install the course(s). For each buoy or marker, align the instrument(s) to the values shown on the worksheet, then coach the positioning crew from the instrument(s) until the buoy or marker is in the correct location.

### **ADDING THE INTEGRATED COURSE**

If you’ve already got a Jump course in place and you want to add an integrated Slalom course, sight the existing 15ET and 15ST gate buoys and input those sightings as your left and right reference markers. Then put the value of 29.5 into cell B11, to align the “theoretical” jump course to those two existing buoys. Then the slalom course sightings which appear on the third page will give you the integrated fit desired—use the shift adjustments in B138 and C138 if needed.

The reverse situation (adding a Jump course to an existing Slalom course) is a little more tedious, since the reference markers are assumed to mark the 15 meter line of the jump course. Your alignment targets will be G4 and G10 of the existing Slalom course, which will also become 19ET and 19ST in the jump course. There’s two ways to proceed—the first would be to actually set 15ET and 15ST, placing these 4m offset from G4 and G10, and in line with those gates. Then sight those as your reference markers and proceed normally.

Alternatively, you could put G4 and G10 sightings into the worksheet as tentative markers, then have the worksheet “fudge up” theoretical sightings which will be 4 meters offset from those—where 15ST and 15ET are intended to go. Put the value of 29.5 into cell B11, then scroll down and put a value of -8 into cell C138. Next write down the theoretical sightings you see for G4 and G10 (on lines 149 and 162). Finally input those theoretical sightings as the reference markers at the top, and reset C138 to zero. Then check to see that the new G4 and G10 theoretical sightings match your actual.



# American Water Ski Association

## TECHNICAL CONTROLLERS' HANDBOOK

Revised 2007

Contributions By: Merle Vasbinder, Tom Dusin, Gene Davis, Dave Clark, Ed Brazil and others.

### CONDUCTING THE SURVY—GENERAL GUIDELINES FOR ALL METHODS.

The AWSA Technical Handbook contains more detail and guidelines on preparing for and conducting such a survey—you should refer to that document unless you are already familiar with surveying techniques and their application to Water Ski sites. Note that a three-point survey is the preferred method, unless the site will not physically accommodate such a procedure.

Standard designation of Slalom Course Sightings: Entrance gate to your left as you face the course from the survey baseline is G1-G2, gate identifiers increase from left to right.

Odd numbered Gate buoys are on the far side of the course, even numbers on the near side. Boat path alignment "Pre-gates" are labeled P1-P2-P15-P16. Skier buoys are also numbered from left to right, S1 therefore is on the near side to your left, and S6 is on the far side to your right. TNL is the Tower on the near shore to your Left (for gate G1-2), and TFR is on the Far shore to your Right (gate G15-G16).

a) Recommended Procedure—Three Point Baseline Survey:

Establish a baseline of two points (about 200-250m apart) along one shore of the lake, from which you can shoot a sighting on each of the listed slalom course targets. Station A is the left end of this line, and C is on the right. When setting up at station A, align the instrument so that station C (to your right) reads 180-0-0. At station C, align so that A reads 0-0-0. Then locate a third base point (B) in between A and C, which may be located on the A-C line if convenient, or may be located ahead of or behind that line—or even on the opposite side of the course, if necessary, although the point should NOT be located DIRECTLY across any of the sighting targets from either of the primary baseline points A or C. At this third point, align so that A reads 0-0-0.

At each station, sight the angle to each of the targets listed on the Slalom data recording form (page 5 of this section), including the base point cross sightings shown on the last line. Read angles in degrees, minutes and seconds, and record these sightings on a copy of the form. You will also need to measure and record the distances between all pairs of the sighting stations, using EDM equipment if you have it, or else a tape.

b) Modified Two Point Baseline Survey:

This is a simplified variant of the above procedure which omits the center sighting station "B"—although note that this may NOT be used to certify a course for Record Capability. Also, sightings to non-timing boat gate buoys (Pre-Gates, G3-G6 and G11-14) may be omitted, in which case the measurement basis centerline will be fitted to the remaining gate buoys.

Except for the differences cited immediately above, the survey procedure is otherwise exactly the same as for the standard three point method, described in the preceding part (a).



# American Water Ski Association

## TECHNICAL CONTROLLERS' HANDBOOK

Revised 2007

Contributions By: Merle Vasbinder, Tom Dusin, Gene Davis, Dave Clark, Ed Brazil and others.

### c) One/Two Point Angle-and-Distance (EDM) Survey:

Establish a survey base point from which you can shoot a sight to each of the slalom course targets, and establish your zero angle to a fixed reference point (to your left as you face the course). Set up your instrument over that base point and align it to zero on the reference point. For Record Capability purposes, you must locate a second shore sighting point from which you can also see all of the course targets, and which can also be sighted from the primary base point. While this point does not need to be on the same side of the course, it should NOT be located DIRECTLY across any of the course buoys from the primary base point.

Sight angle (zero to left, 180 to right) and EDM distance to each of the slalom course buoys, the Judge's towers, and to the secondary sighting station, if applicable. Read angles in degrees, minutes and seconds, and distances in meters to two or three decimal places (or two places if in feet). Record the angle and distance readings for each sighting, using a copy of the supplied recording form (page 5 of these instructions).

This template presumes that your survey instrument is producing uncorrected slope distances for all sightings (except to the secondary sighting point), and will correct these into true horizontal distances internally—although you must either provide an adjustment value (in meters) for the vertical height differential between the EDM instrument and the reflector on the buoy sightings (if your instrument will provide this for you), or else provide the vertical angle on the sighting to entrance gate buoy G1. If your instrument does produce corrected horizontal distances, then simply input these as is, and leave the height adjustment at the zero default.

Where a secondary sighting point has been established (which is required for Record Capability surveys), set up your instrument over the secondary point, align it to zero on any convenient reference point to your left, then shoot sighting angles from this point to each of the listed sighting targets plus the primary base point, and record these in the Station C column.

### **REDUCING THE SURVEY—ALL SURVEY TYPES**

- a) Take the readings obtained in your survey to any IBM PC (or compatible) which has any version of Lotus 1-2-3 (or any other spreadsheet processor which can accept a .WKS type file). If you have a laptop or "Notebook" variety available, bring it to the site with you and reduce your survey right on the spot. Start up your spreadsheet processor and load the appropriate SLMSURVx file (x = 1, 2 or 3, depending on which survey procedure you've followed) from your working copy of the supplied distribution diskette (or from your hard drive if you've installed them this way).



# American Water Ski Association

## TECHNICAL CONTROLLERS' HANDBOOK

Revised 2007

Contributions By: Merle Vasbinder, Tom Dusin, Gene Davis, Dave Clark, Ed Brazil and others.

- b) Enter the Name of the Site and the survey Date in the heading section at the top of the worksheet. For a two-point or three-point baseline survey, input the baseline segment length(s). For a single point survey, you will instead input either the vertical height adjustment, or the vertical angle for the G1 entrance gate sighting. If the course uses smaller-diameter non-spherical interior boat gate buoys, you should reset the interior gate width value (to the right end of the P1 line near the top of the worksheet) to 1.10 meters. Then input the sighting angles (and EDM distances for an angle/distance survey) in the input section. If your baseline or EDM distance values are in feet, enter each value as ".3048\*xxx.xx" (where xxx.xx is the distance in feet to two places). This form will convert the results to the metric system, which is the official measurement basis.

**IMPORTANT NOTE**—If you should enter a set of sighting and/or distance values on the wrong row by mistake, **DO NOT** use the 1-2-3 (or equivalent for other systems) "Move" command to place these values on the proper row—you will have to re-key the data on the proper row, and then enter the correct values for the first row on top of the misplaced ones.

- c) Double check the input section to ensure that each value has been entered into the worksheet correctly—then press the Calculate key (F9) to process the survey reduction. You can review the resulting derivations on the screen by moving the display window around, although it is usually preferable to print the results on paper so that you can see it all at once. The necessary Range and Setup parameters have already been pre-set in the worksheet to print the primary section—which consists of the input area plus the key derivative measures, including both tolerances and highlight flags. All of this information will print on a single sheet of paper.
- d) Examine the printout or screen carefully—any value highlighted with asterisks (\*\*\*\*) is outside the official tolerances for that measurement, according to the current rules. If you are looking at the worksheet on the screen, be sure to scroll over to the right to examine the one or two data columns which are lurking there. Triple check the input data relating to any buoy(s) which are involved in any such out-of-tolerance situations, before starting to move buoys around. Note that the column headed "Sight Err" (three-point baseline survey or two-point EDM survey spreadsheets only) presents the adjusted diameter of the inscribed circle in the error triangle at each target buoy. The allowed tolerance is up to 8 cm (or about three inches) for each target buoy. Large sighting error values indicate any of several different possibilities:
- A Lack of precision in measuring the baseline, or a base-line which deviates significantly from straight (when it was INTENDED for the center station B to be located on the A-C baseline) will cause large triangles throughout the survey.
- Buoys moving around during the survey can be caused by strong or variable winds, or other disturbances of the water during the sightings. Courses anchored in deep water, or buoys which are floating too high, will tend to exaggerate this problem. Occasional or seemingly random large sighting error values are generally of this sort.
- An extremely large sight error probably reflects a data error, either in interpreting the vernier (for instruments so equipped), in recording the angles, or in entering these values into the worksheet. Also, miss identifying one or more of the buoys at





# American Water Ski Association

## TECHNICAL CONTROLLERS' HANDBOOK

Revised 2007

Contributions By: Merle Vasbinder, Tom Dusin, Gene Davis, Dave Clark, Ed Brazil and others.

the time the sightings are being taken can also result in this type of problem. For 3-point baselines which are not in a straight line, there are two checks on your baseline configuration, which are presented on the BSLN row. The sum of the interior angles of a triangle should always add to exactly 180 degrees, and so the first check is to add up the three vertex angles from the station-to-station cross-sightings. The leftmost check value displayed is the amount by which your sum differs from a "theoretically perfect" 180-0-0. Secondly, the spreadsheet then takes the three station-to-station segment lengths that you have provided, derives what the three vertex angles of such a triangle should be, then sums the differences between those derived vertex angles and the actual reported vertex angles from your cross-sightings. The rightmost check value is that sum of the differences (again presented in seconds). See the notes in the worksheet, if either value is flagged.

Note that the section headed "Transformed Coordinates" shows the X (up and down course) and Width locations of each buoy, relative to a least squares best fit centerline down the center of the 8 (or 10) pairs of boat gate buoys. Be aware that if one or more buoys at either end of the course are significantly off their nominal positions, that could result in several other width measures showing out of tolerance, instead of (or in addition to) those of the offending buoy(s).

### e) MAKING CORRECTIONS—NEW FEATURES HERE—CHECK THIS OUT!

This latest revision includes a lot of new features to help you plan and execute corrections to a slalom course. Those features are located to the right of the primary data and derivatives area, at the top of the spreadsheet. To find this section, scroll over to the right, to cell AA1. We've included a control parameter at the top of this section, that controls whether this section works with Metric or English measures. If cell A14 contains a zero, then all error values will be displayed in centimeters, and your inputs are assumed to be expressed in cm as well. If cell A14 contains 1, then the basis for both will be in inches instead of cm. Since the information you cook up in this section will eventually be used to actually move things around later, you should use whichever measurement basis you are more comfortable working with.

The top part of this section includes four sets of columns, arranged from left to right.

The leftmost columns display the unadjusted deviations from ideal placement, of each buoy or object in your survey. The "X-Pos" error column is the deviation in the up-and-down-course direction, and the "Width" error column is in the side-to-side direction. These errors are signed, with Positive values in X-Pos meaning away from the P1-P2 end, and Positive values in Width meaning away from the fitted centerline. Negative values indicate the opposite directions.

At the bottom of each column you will find an MAD (Mean Absolute Deviation) statistic, which is the average of the absolute values of the errors, in that respective direction.

The second set of columns is where you will input your plan of correction movements, with each movement separated into X-Pos and Width components. These are also signed values, with the signs meaning the same directions as cited above.

The third set of columns presents revised errors. Assuming that any correction movements you plan will actually be made, this fits a new centerline to that revised gate layout, and then calculates new error values from that new basis line for each



# American Water Ski Association

## TECHNICAL CONTROLLERS' HANDBOOK

Revised 2007

Contributions By: Merle Vasbinder, Tom Dusin, Gene Davis, Dave Clark, Ed Brazil and others.

object in the revised layout. There are also revised MAD statistics shown at the bottom of each column.

The fourth set of columns displays revised EDM sightings, as would be seen from one of your existing survey stations, for each object for which you have input a correction movement. Once you finalize your movement plan, this data can be used to actually accomplish those specific movements. Note that the EDM Distance values shown for each such sighting will always be expressed in meters—the Centimeters / Inches control parameter at the top, only applies to the deviation and movement plan columns.

Both the Initial and Revised width columns are accompanied by a tolerance check column. The revised section will continue to change, as your movement plan develops. There is also a complete length measurement derivation and check area at the bottom of this section, which reflects all of your planned movements. The content here is almost identical to what is shown in the primary measurement section, except that this area will reflect the effects of your planned corrections.

### RECOMMENDED PROCEDURE TO DEVELOP A CORRECTION PLAN—

Since the fitted centerline is based on the locations of ALL 20 (or 16) gate buoys, moving ANY of these buoys will then also move the centerline, which in turn will affect all of the other deviation values for the whole layout.

Consequently, you need to develop your correction plan in a specific step-by-step fashion, and in a specific sequence. After you enter each planned movement value, you should press the F9 key to recalculate the spreadsheet to reflect that change, and then observe the effect of that change on all the other measurements. Follow that same iterative procedure through the following areas:

- 1) First plan side-to-side corrections in the gate buoys, beginning with those which are most obviously out of line with the others. The objective here is to eliminate all the Width error tolerance checks, and/or to reduce the MAD value which appears at the bottom of the revised Width error column.
- 2) Then plan the up-and-down-course movements of the gate buoys. The objective here is to eliminate all the Length tolerance checks in the Length check area at the bottom of this section, and/or to reduce the MAD value which appears at the bottom of the revised X-Pos error column.
- 3) Once the gate layout has been corrected, THEN you should plan any necessary movements to the skier buoys, based on their relationships to the revised refitted centerline. Use the "Thru Skier Buoys" section at the lower right and the Width errors on those skier buoy rows as guidance, and also check the revised "Skier Buoy Average Width".
- 4) Finally you can figure corrections in your Judges Tower markers, to correct the angle to the final entrance gate locations. It's easiest to plan these corrections in the up-and-down-course direction, although your shoreline configuration may dictate movement in both axis directions, in order to get the angle you want. Note that the Ideal angle is 44 degrees, and the +/- tolerance is 3 degrees—hence the "Good" range is 41-47.





# American Water Ski Association

## TECHNICAL CONTROLLERS' HANDBOOK

Revised 2007

Contributions By: Merle Vasbinder, Tom Dusin, Gene Davis, Dave Clark, Ed Brazil and others.

Then once you're satisfied with your correction plan, you should print out a copy of this section (note the print range cited at the top of this section), and use that data to execute your movements. If you have an EDM instrument, you can guide the corrections using the "Revised Sightings" shown in the rightmost columns, which are figured from one of your existing survey base points.

Alternatively, you can accomplish your corrections thru visual alignment of each buoy to be moved, relative to its adjacent neighbors in both directions. Separate observers (coaches) in both the up-and-down-course and side-to-side directions, will help ensure that those movements are accomplished as intended. As an additional aid to this procedure, the revised spreadsheets also include a visual "Correction Movement Map" section, which you can print out and work from. Scroll over to column BA1 to find this new section and the associated print instructions.

- f) After making any adjustments and/or corrections (and re-shooting all or part of the survey if necessary and re-processing the results), print out a final copy of the worksheet and attach it to the Technical Controller's report from the tournament. Save a copy of the completed worksheet file—but DON'T save it to the original SLMSURVx name (which will wipe out your original master copy of the template), instead save it under a new name which will help you identify it, should you need to access it again at a later date.



# American Water Ski Association

## TECHNICAL CONTROLLERS' HANDBOOK

Revised 2007

Contributions By: Merle Vasbinder, Tom Dusin, Gene Davis, Dave Clark, Ed Brazil and others.

### SLALOM SITE SURVEY DATA RECORDING FORM V3.43 4/2001 (page 8 of 8)

----- Site Description ----- Date A-B B-C A-C (distance)

TARGET BUOY	-- STATION A --			ST B / EDM DIST			-- STATION C--		
	DEG	MIN	SEC	DEG	MIN	SEC	DEG	MIN	SEC
-----	-----	-----	-----	-----	-----	-----	-----	-----	-----
P1									
P2									
G1									
G2									
-----	-----	-----	-----	-----	-----	-----	-----	-----	-----
G3									
G4									
S1									
-----	-----	-----	-----	-----	-----	-----	-----	-----	-----
S2									
G5									
G6									
-----	-----	-----	-----	-----	-----	-----	-----	-----	-----
G7									
G8									
S3									
-----	-----	-----	-----	-----	-----	-----	-----	-----	-----
S4									
G9									
G10									
-----	-----	-----	-----	-----	-----	-----	-----	-----	-----
G11									
G12									
S5									
-----	-----	-----	-----	-----	-----	-----	-----	-----	-----
S6									
G13									
G14									
-----	-----	-----	-----	-----	-----	-----	-----	-----	-----
G15									
G16									
P3									
P4									
-----	-----	-----	-----	-----	-----	-----	-----	-----	-----
TNL									
TFR									
-----	-----	-----	-----	-----	-----	-----	-----	-----	-----
BSLN		A-B			B-C			C-B	
-----	-----	-----	-----	-----	-----	-----	-----	-----	-----

DESIGNATION & ORIENTATION STANDARDS (all left and right as you face the course) -- Station A and zero angle to your left on baseline; G1-G2 entrance gate to your left, G15-G16 to your right. Odd gate buoy numbers on far side, even on near. Skier buoys (Sx) numbered 1 thru 6 from the left entrance gate. Boat path alignment "Pre-gates" (Px) outside entrance gates at either end. Judges' Tower TNL is on the near shore to your Left (for Gate G1-G2), and TFR is on the Far shore to your Right (for Gate G15-G16). BSLN are the A-B, B-C & C-B baseline cross sightings (REQUIRED Alignment: A-C=180, B-A=0, C-A=0)



# American Water Ski Association

## TECHNICAL CONTROLLERS' HANDBOOK

Revised 2007

Contributions By: Merle Vasbinder, Tom Dusin, Gene Davis, Dave Clark, Ed Brazil and others.

### **JUMPING SITE SURVEY AND REDUCTION INSTRUCTIONS**

---

#### **CONDUCTING THE SURVEY—General guidelines for all methods.**

The AWSA Technical Handbook contains more detail and guidelines on preparing for and conducting such a survey—you should refer to that document unless you are already familiar with surveying techniques and their application to Water Ski sites. Note that a three-point survey is the preferred method, unless the site will not physically accommodate such a procedure.

All of the JMPSURVx variations provided here include support for the setup and verification of both the Johnson Jump Meter System, and the Corson Video Jump Distance Measurement System. Look at the Jump Site data recording form which is the last page of this section of these instructions, and study the object designation and orientation notes which appear at the bottom of that form. Note that the bottom-most recording section may serve either the Meter OR Video systems. Those lines labeled Mt/Ck-A+ in that input section, are to be used either for Meter station pivot sightings when a meter system is being used, or for Video Check buoys with the video system. Similarly, the cell labeled Tst/Cam is to be used as the meter alignment/test point sighting for a meter system, or to identify a video camera location when video measurement is being used.

Sighting targets for all Jump Site survey variants include a wide variety of objects. On the water, these include 8 to 10 boat gate buoys (the ST, MT, ET and EC gates are required, the AG is optional), along with the 150/180/210 skier buoys, the inside and outside high end corners of the jump ramp plus the sighting mark at the center of the ramp (if present), and possibly a grid of Video system reference and check buoys in the jump landing area. On shore, these include the sighting arm pivots on all 3 jump meter stations, plus a meter sighting alignment/test point which should be located across from the meters near the center of the landing zone, and possibly one or more video camera support locations. Finally, the preferred method for establishing the rotation of the jump ramp is to place an additional marker on shore, along a line extended sideways off the high end of the ramp—this object is designated HEXM.



# American Water Ski Association

## TECHNICAL CONTROLLERS' HANDBOOK

Revised 2007

Contributions By: Merle Vasbinder, Tom Dusin, Gene Davis, Dave Clark, Ed Brazil and others.

### **CONDUCTING THE SURVEY—Specifics for each alternative method.**

a) Recommended Three Point Baseline Survey:

Establish a baseline of two points (about 200-250m apart) along one shore of the lake, from which you can shoot a sighting on each of the listed Jumping site targets.

Station A is the left end of this line, and C is on the right. When setting up at station A, align the instrument so that station C (to your right) reads 180-0-0. At station C, align so that A reads 0-0-0. Then locate a third base point (B) in between A and C, which may be located on the A-C line if convenient, or may be located ahead of or behind that line—or even on the opposite side of the course, if necessary, although the point should NOT be located DIRECTLY across any of the sighting targets from either of the primary baseline points A or C. At this third point, align so that A reads 0-0-0.

At each station, sight the angle to each of the targets listed on the Jumping data recording form (page 6 of this section), including the base point cross sightings shown on the last line. Read angles in degrees, minutes and seconds, and record these sightings on a copy of the form. You will also need to measure and record the distances between all pairs of the sighting stations, using EDM equipment if you have it, or else a tape.

b) Modified Two Point Baseline Survey:

This is a simplified variant of the above three-point procedure which only uses two stations instead of three—although you should note that this variant may NOT be used to certify a course for Record Capability purposes. The survey procedure is otherwise exactly the same as the standard three-point method, described in part (a) above.

c) One/Two Point Angle-and-Distance (EDM) Survey:

Establish a survey base point from which you can shoot a sight to each of the targets specified above, and establish your zero angle to a fixed reference point (to your left as you face the course). Set up your instrument over that base point and align it to zero on the reference point. For Record Capability purposes, you must locate a second shore sighting point from which you can also see all of the sighting targets, and which can also be sighted from the primary base point. While this point does not need to be on the same side of the course, it should NOT be located DIRECTLY across any of the sighting targets from the primary base point.

Sight angle (zero to left, 180 to right) and EDM distance to each of targets specified above. Read angles in degrees, minutes and seconds, and distances in meters to two or three decimal places. If your instrument only registers in feet, two decimal places is sufficient. Record the angle and distance readings to each point on a copy of the Jumping Site Recording form which is incorporated in these instructions.

This template presumes that your survey instrument is producing uncorrected slope distances for all sightings, and will correct these into true horizontal distances internally—although you must either provide adjustment values (in meters) for the vertical height differential between the EDM instrument and the reflector at the 180M



# American Water Ski Association

## TECHNICAL CONTROLLERS' HANDBOOK

Revised 2007

Contributions By: Merle Vasbinder, Tom Dusin, Gene Davis, Dave Clark, Ed Brazil and others.

buoy plus the various shore-based targets (if your instrument will provide these for you), or else provide the vertical angle on these sightings. These vertical angles or height adjustments should be recorded in the Station B column on the data recording form. If your survey instrument does produce corrected horizontal distances, then simply input these as is and leave the adjustment values at their defaults.

Where a secondary sighting point has been established (which is required for Record Capability surveys), set up your instrument over this secondary point, align it to zero on any convenient point to your left, then shoot sighting angles from this point to each of the various sighting targets plus the primary base-point, and record these sightings in the Station C Column.

### **REDUCING THE SURVEY—All Survey types.**

- a) Take the readings obtained in your survey to any IBM PC (or compatible) which has any version of Lotus 1-2-3, Excel (or any other spreadsheet processor which is capable of loading a .WKS type file). If you have a laptop or "Notebook" variety available, bring it with you and reduce your survey right at the site. Start up your spreadsheet processor and load the appropriate JMPSURVx file (x = 1, 2 or 3, depending on which survey procedure you've followed) from your working copy of the supplied distribution diskette (or from your hard drive if you've installed them this way).
- b) Enter the Name of the Site and the survey Date in the heading section at the top of the worksheet, and then indicate in that same section which shore the survey was shot from, and which shore the meters are on. For a two-point or three-point baseline survey, input the baseline segment length(s). Then input the various sighting angles (plus the EDM distance values and height adjustments or vertical angles for an angle/distance survey) in the input section. If your baseline or EDM distance values are in feet, enter each value as ".3048\*xxx" (where xxx is the distance in feet to two places). This will convert the results to the metric system, which is the official measurement basis. For an EDM survey, input the Vertical Height adjustment values (or vertical angles) on the 180M sighting row, as well as for all the shore-based points, which include the ramp alignment point, the meter test point and the meter pivots.

**IMPORTANT NOTE**—If you should enter a set of sighting and/or distance values on the wrong row by mistake, DO NOT use the 1-2-3 (or equivalent for other systems) "Move" command to place these values on the proper row—you will have to re-key the data on the proper row, and then enter the correct values for the first row on top of the misplaced ones.

- c) Double check the input section to ensure that each value has been entered into the worksheet correctly—then press the Calculate key (F9) to process the survey reduction. You can review the resulting derivations on the screen by moving the display window around, although it is usually preferable to print the results on paper so that you can see it all at once. The necessary Range and Setup parameters have already been pre-set in the worksheet to print the primary section—which consists of



# American Water Ski Association

## TECHNICAL CONTROLLERS' HANDBOOK

Revised 2007

Contributions By: Merle Vasbinder, Tom Dusin, Gene Davis, Dave Clark, Ed Brazil and others.

the input area plus the key derivative measures, including both tolerances and highlight flags. All of this information will print on a single sheet of paper.

- d) Examine the printout or screen carefully—any value highlighted with asterisks (\*\*\*\*) is outside the official tolerances for that measurement, according to the official rules. If you are looking at the worksheet on the screen, be sure to scroll over to the right to examine the one or two data columns which are lurking there. Triple check the input data relating to any buoy(s) which are involved in any such out-of-tolerance situations, before starting to move buoys around.

Note that the column headed “Sight Err” (three-point baseline survey or two-point EDM survey spreadsheets only) presents the adjusted diameter of the inscribed circle in the error triangle at each target buoy. The allowed tolerance is up to 8 cm (about three inches) for buoy and ramp sightings, and half that amount for the shore-based targets. See page 4 of the Slalom Course section of these instructions for a discussion of the causes of large sighting error values, or for an explanation of the check values presented on the BSLN row.

Note that the section headed “Transformed Coordinates” shows the X (up and down course) and Y (side to side) locations of each buoy and the ramp, relative to a least squares best fit centerline down the 15 Meter line of the timing course. You should be aware that if one or more buoys at either end of this line are significantly off their nominal positions, that could result in several other measures showing out of tolerance, instead of (or in addition to) the errors on the 15 meter line showing up. Consider this when evaluating the results.

- e) After making any adjustments and/or corrections (and re-shooting all or part of the survey if necessary and re-processing the results), print out a final copy of the worksheet and attach it to the Technical Controller's report from the tournament. Save a copy of the completed worksheet file—but DON'T save it to the original JMPSURVx name (which will wipe out your original master copy of the template), instead save it under a new name which will help you identify it, if and when you need to access it again at a later date.
- f) Use the Meter Setup data which appears in the bottom right portion of the completed worksheet to align the protractors on the meter tables. Align the protractor on each meter station so that a sighting to the test point indicates the value shown on the worksheet. This will result in a metering system that will function most accurately in the actual operating range. As an additional check, actual sightings to the ramp and to 15ET should also match the worksheet values, although again the test point values are the preferred basis to use for protractor alignment, as long as you have selected a clearly visible test point which is out in front of the meters across the area in which the jumpers will actually be landing.



# American Water Ski Association

## TECHNICAL CONTROLLERS' HANDBOOK

Revised 2007

Contributions By: Merle Vasbinder, Tom Dusin, Gene Davis, Dave Clark, Ed Brazil and others.

- g) The Meter setup information mentioned above also provides the parameters required to prepare the WSTIMS system to calculate jump distances for this site, and is also the same data which is needed in order to prepare a manual masterboard (as a backup device, in the event you do not have an independently-powered backup computer system available).
  
- h) The Video Reference Sightings (VRL1, VRR1, VRL2, VRR2, etc) are provided to establish the water surface coordinates of up to 8 individual reference marker buoys for the Corson Video Jump Measurement System. There are also input cells provided for up to 3 video check buoys, plus a video camera location (on shore). The derived coordinates of these locations are presented on the left side of the second page of the results, and have been translated into a framework which has the ramp center as the assumed (0, 0) origin point. These are the preferred values for input to the CVJ Grid Setup screen.



# American Water Ski Association

## TECHNICAL CONTROLLERS' HANDBOOK

Revised 2007

Contributions By: Merle Vasbinder, Tom Dusin, Gene Davis, Dave Clark, Ed Brazil and others.

### JUMPING SITE SURVEY DATA RECORDING FORM V3.43 4/2001 (page 6 of 6)

----- Site Description ----- Date A-B B-C A-C (distance)

TARGET BUOY	-- STATION A --			ST B / EDM DIST			ST C / VERT ANG		
	DEG	MIN	SEC	DEG	MIN	SEC	DEG	MIN	SEC
210M	----	----	----	----	----	----	----	----	----
180M	----	----	----	----	----	----	----	----	----
150M	----	----	----	----	----	----	----	----	----
15SC	----	----	----	----	----	----	----	----	----
19SC	----	----	----	----	----	----	----	----	----
15ST	----	----	----	----	----	----	----	----	----
19ST	----	----	----	----	----	----	----	----	----
15MT	----	----	----	----	----	----	----	----	----
19MT	----	----	----	----	----	----	----	----	----
15ET	----	----	----	----	----	----	----	----	----
19ET	----	----	----	----	----	----	----	----	----
15EC	----	----	----	----	----	----	----	----	----
19EC	----	----	----	----	----	----	----	----	----
ROHC	----	----	----	----	----	----	----	----	----
RIHC	----	----	----	----	----	----	----	----	----
RCTR	----	----	----	----	----	----	----	----	----
HEXM	----	----	----	----	----	----	----	----	----
VRL1	----	----	----	----	----	----	----	----	----
VRR1	----	----	----	----	----	----	----	----	----
VRL2	----	----	----	----	----	----	----	----	----
VRR2	----	----	----	----	----	----	----	----	----
VRL3	----	----	----	----	----	----	----	----	----
VRR3	----	----	----	----	----	----	----	----	----
VRL4	----	----	----	----	----	----	----	----	----
VRR4	----	----	----	----	----	----	----	----	----
TST/CAM	----	----	----	----	----	----	----	----	----
MT/CK-A	----	----	----	----	----	----	----	----	----
MT/CK-B	----	----	----	----	----	----	----	----	----
MT/CK-C	----	----	----	----	----	----	----	----	----
BSLN	----	A-B	----	----	B-C	----	----	C-B	----

DESIGNATION & ORIENTATION STANDARDS -- 15xx buoys are those closest to ramp. ROHC and RIHC are the Outside and Inside high end corners of the ramp (in=closest-to-gates). Rctr is the Ramp Center (omit if no center mark). HEXM is a mark on shore extended across the high end of ramp, to derive rotation. VJ ref buoys are coded L/R as seen fm ramp, in rows down course. Use Mt/Ck-A/B/C for Jump Mtrs or Video Ck buoys (Mtr A is closest to ramp). Tst/Cam is Test Pt across landing area for Mtrs, or Video Camera loc. BSLN are the A-B, B-C and C-B baseline cross sightings (REQUIRED Alignment: A-C=180, B-A=0, C-A=0)





# American Water Ski Association

## TECHNICAL CONTROLLERS' HANDBOOK

Revised 2007

Contributions By: Merle Vasbinder, Tom Dusin, Gene Davis, Dave Clark, Ed Brazil and others.

### Slalom Survey Exercise

The following is intended to offer practical experience for using and understanding the Survey reduction spreadsheets employed to calculate the data collected during a 3 point survey. This will require the user to download the current version of **wssurv34.exe** located on the internet at [www.awsaeast.org](http://www.awsaeast.org) .

#### Slalom Survey Analysis Exercise -- Including Sample Sighting Data

-----

This exercise has been created to help a survey user to become more familiar with the Slalom Survey tools, and how to use these to deal with a slalom course in need of adjustment.

Cut and paste the data below, into the "Sighting Values" section of the 3-point slalom survey spreadsheet template SLMSURV3.WKS. Then identify and correct a few errors that exist in this input data -- look for sighting error and baseline check flags. You should have enough information here to be able to figure out what those errors are and to correct them -- here are some hints to help you.

- (1) For one of the baseline cross-sightings, the minutes and seconds values were reversed when they were recorded.
- (2) You will see a pair of large sighting errors on one of the interior gates. The problem occurred at one of the three base stations, the recordings of those two sightings were reversed. By visualizing the setup at each station, and how that particular string (S2-G5-G6) would appear from each, you should be able to figure out and correct this error.
- (3) The large sighting error on G14 is due to the degrees value on one of the three sightings having been read wrong by one degree. As above, visualize what the S6-G13-G14 string should look like from each station, and that will help you identify where the error is.

Once your input data is "good", then study the slalom course itself -- you will find a several "Out of Tolerance" conditions.

Use the "Correction Planning" features of the spreadsheet to develop a correction plan for this course.

Refer to the instructions included in the spreadsheet itself. Note that a "minimally acceptable" course can be produced by moving only 9 of the 28 buoys. Moving an additional 8 would result in a course where everything is within 5cm (2 inches) of ideal.

You are encouraged to develop both a "Minimally Acceptable" correction plan, and then another "More Idealistic" correction plan, and print out the "Movement Map" for each of these.

Baseline Lengths



# American Water Ski Association

## TECHNICAL CONTROLLERS' HANDBOOK

Revised 2007

Contributions By: Merle Vasbinder, Tom Dusin, Gene Davis, Dave Clark, Ed Brazil and others.

### Angular Sighting Input Values

Buoy Tar- get:	Station A			Station B			Station C			
	Deg	Min	Sec	Deg	Min	Sec	Deg	Min	Sec	
P1	79	18	45	17	52	20	17	25	40	
P2	79	3	80	17	8	30	16	51	50	
G1	123	16	85	358	21	30	21	30	0	
G2	124	20	40	357	47	10	20	42	35	
G3	138	5	80	345	26	50	24	30	5	
G4	139	6	70	345	11	50	23	40	5	
S1	144	11	75	344	2	0	19	55	0	
S2	148	8	45	322	40	50	36	20	0	
G5	151	58	65	323	46	30	30	44	0	
G6	152	49	90	323	58	10	31	44	45	
G7	159	50	85	304	38	30	45	50	0	
G8	160	34	65	305	7	0	44	35	50	
S3	164	3	70	307	9	0	38	10	45	
S4	162	1	90	287	39	30	79	9	10	
G9	164	48	65	290	33	50	76	13	45	
G10	165	24	95	291	10	0	75	24	20	
G11	168	8	60	280	53	10	120	0	35	
G12	168	40	70	281	28	50	121	2	35	
S5	171	5	50	283	57	50	126	53	40	
S6	168	27	45	271	43	50	141	15	10	
G13	170	30	85	274	11	10	146	31	20	
G14	171	59	75	274	44	40	147	50	15	
G15	171	45	60	270	50	40	155	39	40	
G16	172	11	65	271	24	20	156	44	45	
P15	173	42	50	265	48	40	165	28	15	
P16	174	4	80	266	18	10	166	16	35	
TNL	175	35	0	329	19	20	4	10	20	
TFR	161	10	25	265	3	40	122	28	10	
BSLN	120	40	45	297	7	30	57	53	15	
A to B	194.231									
B to C	197.05									
A to C	204.091									



# American Water Ski Association

## TECHNICAL CONTROLLERS' HANDBOOK

Revised 2007

Contributions By: Merle Vasbinder, Tom Dusin, Gene Davis, Dave Clark, Ed Brazil and others.

### Sample Dossier

International Water Ski Federation  
2006 Edition Homologation Dossier

#### IMPORTANT NOTICE:

It is not the intent of this form to add hours of extra work to the Homologator job, but rather to provide a quick checklist that gives visibility of the technical effort to the general skiing public.

#### START OF HOMOLOGATION FORM

Code of competition: \_\_\_\_\_ code of site: \_\_\_\_\_

Name of competition: \_\_\_\_\_

Date: \_\_\_\_\_

Venue: \_\_\_\_\_

Organizing Country: \_\_\_\_\_

Type of competition ( \_\_\_\_\_ )

Were cash prizes or merchandise awarded (Yes/No) ( \_\_\_\_\_ ) Amount: \_\_\_\_\_

Homologator and Chief Judge Recommendation to Tournament Council  
(Fill in R-Record, L-Standing List, N-Not list capable)

Event	Round 1	Round 2	Round 3	Round 4
Slalom	( )	( )	( )	( )
Tricks	( )	( )	( )	( )
Jump	( )	( )	( )	( )

#### OBLIGATORY COMPOSITION OF DOSSIER:

1 copy of this document including the homologation notice

#### HOMOLOGATOR'S CHECKLIST

If checked and all according to rules put OK in brackets. If checked and any variation to the rules put an X in the brackets and explain in "Remarks" section on last page. Not applicable is NA.

1. Boats and equipment (W 10.01) ( )

2. Speed Control (W 10.07) ( )

Manufacturer: \_\_\_\_\_

Software Version: \_\_\_\_\_

Slalom ( )

Tricks ( )

Jump ( )



# American Water Ski Association

## TECHNICAL CONTROLLERS' HANDBOOK

Revised 2007

Contributions By: Merle Vasbinder, Tom Dusin, Gene Davis, Dave Clark, Ed Brazil and others.

- 3. Arrangement for checking skis (W 10.03) ( )
  - 4. Measure lines and handles (W 10.04) ( )
    - Slalom ( )
    - Jump ( )
    - Handles ( )
  - 5. Arrangement for checking of skier
    - Supplied handles (W 10.06) ( )
  - 6. Timing devices (W 11.03) ( )
  - 7. Homologation notice posted before start ( )
  - 8. Automatic timing-jump ( ) Optional Timing Method ( )
  - 9. Jump distance indication (W 13.11) ( )
  - 10. Video Jump Distance measurement (W 13.11) ( )
    - Backup - video tape or standard meters ( )
  - 11. Automatic timing-slalom Dual Segment ( )
    - All Buoys ( )
  - 12. Position and height of slalom towers (W 14.05 and W diagram 6) ( )
  - 12a. Slalom Officials ( )
  - 13. Slalom buoys (W 14.06) ( )
  - 14. VHS video slalom end course (W 14.17) ( )
  - 15. Trick course checked (W diagram 3) ( )
  - 16. Position and height of trick towers (W 15.11) ( )
  - 16a. 5 Judges ( ) 1 x 3 Judges with video ( ) 2x 3 Judges with video ( )
  - 17. Semi-automatic timing-20sec (W 15.12) ( ) automatic median start ( )
  - 17a. Video Tricks Timing ( ) with Additional judge ( ) Chief Judge ( )
  - 18. VHS video tricks (W15.15) ( )
  
  - 19a. Video Tricks Timing system manufacturer ( )
  - 20. 2nd Speed Control Display used all events ( )
- SLALOM COURSE TYPE :

### JUMP COURSE

### JUMP MEASUREMENT SETUP

#### VIDEO JUMP

##### 40m Test buoy

Survey x (XXX.XX) y (XXX.XX)  
Video system x (XXX.XX) y (XXX.XX)

##### 60m Test buoy

Survey x (XXX.XX) y (XXX.XX)  
Video system x (XXX.XX) y (XXX.XX)



# American Water Ski Association

## TECHNICAL CONTROLLERS' HANDBOOK

Revised 2007

Contributions By: Merle Vasbinder, Tom Dusin, Gene Davis, Dave Clark, Ed Brazil and others.

### JUMP RAMP

Width at top (W 13.02a)	X.XX m
Width at bottom	X.XX m
Top edge to 6.4m line left side (W 13.02b, h)	X.XX m
Top edge to 6.4m line right side (W 13.02b.h)	X.XX m
Top edge to 6.7m line left side (W 13.02b, h)	X.XX m
Top edge to 6.7m line right side (W 13.02b.h)	X.XX m
Length underwater from 6.7m line (W 13.02c)	X.XX m

### Maximum Deviation from plane

Diagonal string measurement (W 13.02f)	X.X cm
Center string measurement (W 13.02f)	X.X cm

### (OK/X)

Apron under water (W 13.02g)	( )
Apron full length (W 13.02g)	( )
Sighting line (W 13.02i)	( )
Secure anchoring (W 13.02i)	( )

### Apron Angle (W 13.02k)

Jump height	X.XX m (a)
Length of edge of apron from top corner to water	X.XX m (b)

Ratio of b/a	(X.XXX)	( )
Minimum 0.883	maximum 0.643	

### RAMP SETTING

Setting	Right Side		Left Side		Ratio
	Height	Length	Height	Length	
1.50	XXX.X	XXX.X	XXX.X	XXX.X	XXX.X
1.65	XXX.X	XXX.X	XXX.X	XXX.X	XXX.X
1.80	XXX.X	XXX.X	XXX.X	XXX.X	XXX.X

### NON-VIDEO JUMP

Note: The following section is only to be completed if the jumps were measured by protractors rather than video.

Automatic meter system used (Yes/No) ( )

Protractor reading units (Degrees/Grades) ( )



# American Water Ski Association

## TECHNICAL CONTROLLERS' HANDBOOK

Revised 2007

Contributions By: Merle Vasbinder, Tom Dusin, Gene Davis, Dave Clark, Ed Brazil and others.

### METER SETUP

Distance (T1 - T2/A - B) (XXX.XX meters)  
 Distance (T2 - T3/B - C) (XXX.XX meters)  
 If not a straight line  
 Distance (T1 - T3/A - C) (XXX.XX meters)

Inter-meter angles (if not a straight line)

	T1/A	T2/B	T3/C
Meter T1/A	XXXXX	180.0	180.0
Meter T2/B	0.0	XXXXX	180.0
Meter T3/C	0.0	0.0	

(Note shown numbers are examples - fill in with actual numbers)

### SET UP SIGHTINGS

Angle	Ramp	15ET
T1/A upper	XXX.X	XXX.X
T1/A lower	XXX.X	XXX.X
T2/B upper	XXX.X	XXX.X
T2/B lower	XXX.X	XXX.X
T3/C upper	XXX.X	XXX.X
T3/C lower	XXX.X	XXX.X

Using average of upper and lower readings (max difference 0.1 degrees) list the error triangles with an inscribed circle diameter (max 0.15)

Inscribed circle diameter at ramp X.XX meters  
 Inscribed circle diameter at 15ET X.XX meters

Jump system survey results (X-Y coordinates)

	X	Y
Ramp	XXX.XX	XXX.XX
Table 1/A	XXX.XX	XXX.XX
Table 2/B	XXX.XX	XXX.XX
Table 3/C	XXX.XX	XXX.XX
Buoy 15ET	XXX.XX	XXX.XX

Attach the computer printout file  
 at the end after the Homologation Notice

Computer program checked against (OK/X)  
 "Computer Benchmark for Computed Distances"

( )



# American Water Ski Association

## TECHNICAL CONTROLLERS' HANDBOOK

Revised 2007

Contributions By: Merle Vasbinder, Tom Dusin, Gene Davis, Dave Clark, Ed Brazil and others.

### METER STATIONS

Stability and horizontal level	( )
Protractors on same vertical line	( )
Protractor graduations (max 0.2 degrees)	( )
Radius of protractors (min 0.25 m)	( )
Accuracy of sighting arms	( )

### END OF HOMOLOGATION FORM

It is important to leave the above section in the exact format as it will be processed automatically. The following section is where free form comments are added and attachments are made.

### HOMOLOGATOR'S REMARKS

Give details of any variations of IWSF rules. List any alterations to the course, etc. during the competition. List any malfunction of equipment. Give any further information which might affect the Tournament Council's assessment of the homologation.

Homologator:  
(Name and address)

Email:

Chief Judge:  
(Name and address)

This homologation record has been emailed to Bob Corson, [bcorson@comcast.net](mailto:bcorson@comcast.net) for EAME: email also to Marc Raymond, [SKIRAYMO@aol.com](mailto:SKIRAYMO@aol.com)



# American Water Ski Association

## TECHNICAL CONTROLLERS' HANDBOOK

Revised 2007

Contributions By: Merle Vasbinder, Tom Dusin, Gene Davis, Dave Clark, Ed Brazil and others.

### Sample Homologation Notice

#### HOMOLOGATION NOTICE

Tournament Name:

Date:

We recommend to the IWSF Tournament Council the following class of homologation:

Event	Round 1	Round 2	Round 3	Round 4
Slalom	( )	( )	( )	( )
Tricks	( )	( )	( )	( )
Jump	( )	( )	( )	( )

Speed Control Manufacturer:

Software Version:

Mode for tricks (if applicable): \_\_\_\_\_

Date                    \_\_\_\_\_    \_\_\_\_\_    \_\_\_\_\_

Time                    \_\_\_\_\_    \_\_\_\_\_    \_\_\_\_\_

Chief Judge

Homologator

\_\_\_\_\_

Note: These recommendations may change during the competition.

Remarks: